

MODEL: CK-400

SINGLE NEEDLE, UNISON-FEED, CYLINDER BED, LOCKSTITCH
MACHINE FOR EXTRA HEAVY-WEIGHT MATERIALS

單針極厚筒型綜合送料縫紉機

INSTRUCTION MANUAL

操作手冊



INSTRUCTION MANUAL 操作手冊

1.	IMPORTANT SAFETY INSTRUCTIONS	24
2.	SPECIFICATIONS	25
3.	INSTALLING THE HANDWHEEL	25
4.	INSTALLING THE BELT COVER	25
5.	CLEANING	26
6.	LUBRICATION	26
7.	HOW TO INSTALL THE NEEDLE	27
8.	HOW TO TAKE OUT THE BOBBIN	27
9.	HOW TO INSTALL THE BOBBIN	28
10.	HOW TO THREAD THE MACHINE HEAD	28
11.	ADJUSTING THE STITCH LENGTH AND REVERSE STITCHING	29
12.	THREAD TENSION	29
13.	THE THREAD TAKE-UP SPRING	29
14.	ADJUSTING THE PRESSER FOOT PRESSURE	30
15.	ADJUSTING THE HEIGHT OF THE FEED DOG	30
16.	ADJUSTING THE NEEDLE-TO-SHUTTLE RELATIONSHIP	31
17.	ADJUSTING THE WALKING FOOT AND THE PRESSER FOOT	34
18.	THE FEED DOG-TO-NEEDLE RELATIONSHIP	35
19.	THE MOTOR PULLEY AND THE V BELT	36
20.	PROBLEMS WITH SEWING AND CORRECTIVE MEASURES	37

1. IMPORTANT SAFETY INSTRUCTIONS

Putting sewing systems into operation is prohibited until it has been ascertained that the sewing systems in which these sewing machines will be built into, have conformed with the safety regulations in your country. Technical service for those sewing systems is also prohibited.

1. Observe the basic safety measures, including, but not limited to the following ones, whenever you use the machine.
2. Read all the instructions, including, but not limited to this instruction manual before you use the
3. Use the machine after it has been ascertained that it conforms with safety rules/standards valid in
4. All safety devices must be in position when the machine is ready for work or in operation. The operation without the specified safety devices is not allowed.
5. This machine shall be operated by appropriately-trained operators.
6. For your personal protection, we recommend that you wear safety glasses.
7. For the following, turn off the power switch or disconnect the power plug of the machine from the
 - ✓ For threading needle(s), looper, spreader etc. and replacing bobbin.
 - ✓ For replacing part(s) of needle, presser foot, throat plate, feed dog etc.
 - ✓ For replacing part(s) of looper, spreader, needle guard, folder, cloth guide etc.
 - ✓ For repair work.
 - ✓ When leaving the working place or when the working place is unattended.
 - ✓ When using clutch motors without applying brake, it has to be waited until the motor
8. If you should allow oil, grease, etc. used with the machine and devices to come in contact with your eyes or skin or swallow any of such liquid by mistake, immediately wash the contacted areas
9. Tampering with the live parts and devices, regardless of whether the machine is powered, is
10. Repair, remodeling and adjustment works must only be done by appropriately trained technicians or specially skilled personnel. Only spare parts designated by *CHIKON* can be used for repairs.
11. General maintenance and inspection works have to be done by appropriately trained personnel.
12. Repair and maintenance works of electrical components shall be conducted by qualified electric technicians or under the audit and guidance of specially skilled personnel.
13. Before making repair and maintenance works on the machine equipped with pneumatic parts such as an air cylinder, the air compressor has to be detached from the machine and the compressed air supply has to be cut off. Existing residual air pressure after disconnecting the air compressor from the machine has to be expelled. Exceptions to this are only adjustments and performance checks done by appropriately trained technicians or specially skilled personnel.
14. Periodically clean the machine throughout the period of use.
15. Grounding the machine is always necessary for the normal operation of the machine. The machine has to be operated in an environment that is free from strong noise sources such as high-
16. An appropriate power plug has to be attached to the machine by electric technicians. Power plug has to be connected to a grounded receptacle.
17. The machine is only allowed to be used for the purpose intended. Other used are not allowed.
18. Remodel or modify the machine in accordance with the safety rules/standards while taking all the effective safety measures. *CHIKON* assumes no responsibility for damage caused by remodeling or modification of the machine.

2. SPECIFICATIONS

Usage	Pouches, bags, shoes, bag handles, safety belts, etc.	Needle to be used	Schmetz 794 Nm230
		Needle system	Nm130 ~ Nm280
Sewing speed	Max. 800 s.p.m.	Thread	#00 ~ #8
Stitch length	Max. 11 mm	Stitch adjusting method	Lever nut type
Lift of presser foot	Hand lifter 12 mm, Knee lifter 20 mm	Lubrication method	Hand oiling
Thread take-up lever	Cam-type thread take-up lever	Motor to be used	3-phase/single phase 400W clutch motor (4P)
Needle bar stroke	56 mm	Oil to be used	New Defrix Oil No. 1

3. INSTALLING THE HANDWHEEL

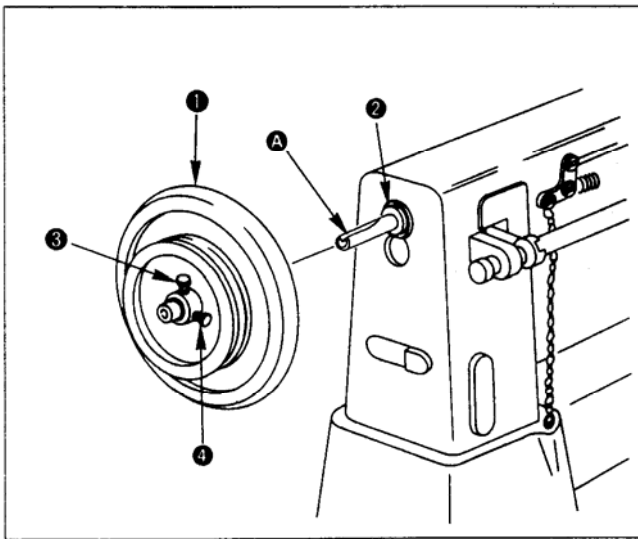

1. Fit handwheel ① close to the main shaft bushing, rear ②.
2. Align the handwheel with thread groove A in the main shaft. Tighten the first screw ③ of the handwheel, then tighten screw ④.

4. INSTALLING THE BELT COVER

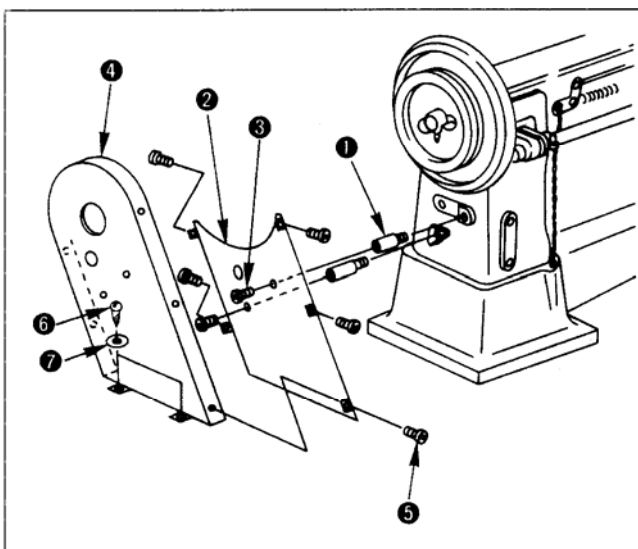

1. Install two belt cover supports ① to the machine arm.
2. Install belt cover B ② to belt cover supports ① using screws ③.
3. Attach belt cover A ④ to belt cover B ② using screws ⑤.
4. Fix belt cover A ④ on the table using wooden screw ⑥ and washer ⑦.

5. CLEANING

Waste thread, dust, dirt, etc., build-up around the feed dog or the shuttle may cause malfunction of the machine. Clean periodically according to your frequency of use.

1. Clean around the feed dog after removing the throat plate.
2. Clean the inside of the shuttle race body by taking out the shuttle body after removing the cover of the shuttle race body.

6. LUBRICATION

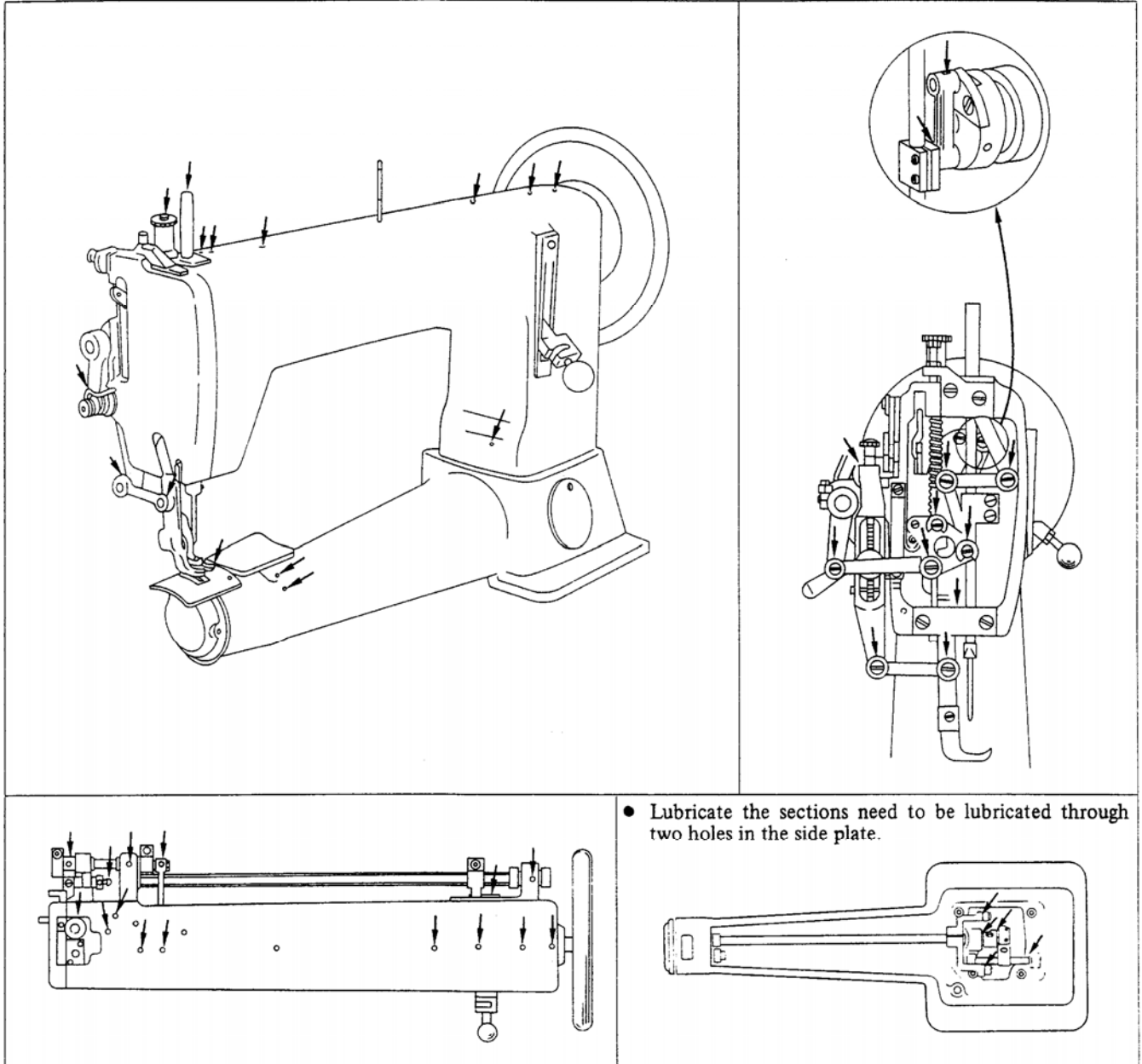

- Lubricate the sections need to be lubricated through two holes in the side plate.

1. After uncrating, supply oil to the machine after cleaning it thoroughly.
2. When oiling all the sections requiring lubrication, after installation of the machine has been completed, wait for a while (approximately 10 minutes) so that oil can penetrate each section sufficiently before starting continuous operation.
3. To operate the machine continuously, apply two to three drops of oil to each section noted with an arrow mark in the following figure whenever starting operation in the morning and in the afternoon.

7. HOW TO INSTALL THE NEEDLE

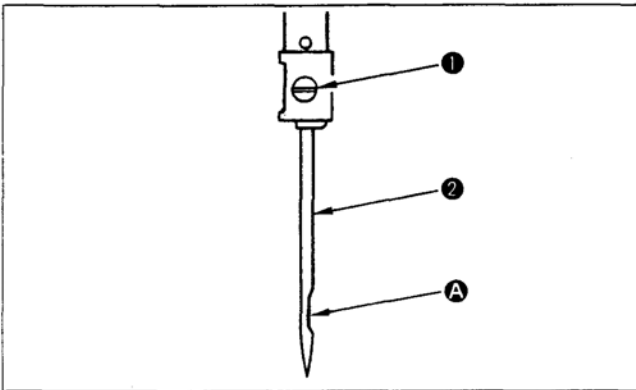

★ Be sure to power-off the motor.

The standard needle is a Schmetz 794, however an Organ DY x 3 can be used.

1. Turn the handwheel by hand and raise the needle bar to its top position.
2. Loosen screw ① and insert the needle ② into the hole until it will go no further.
(Insert the needle with its recess ③ facing directly to the right-hand side.)
3. Securely tighten the screw in the needle.

8. HOW TO TAKE OUT THE BOBBIN

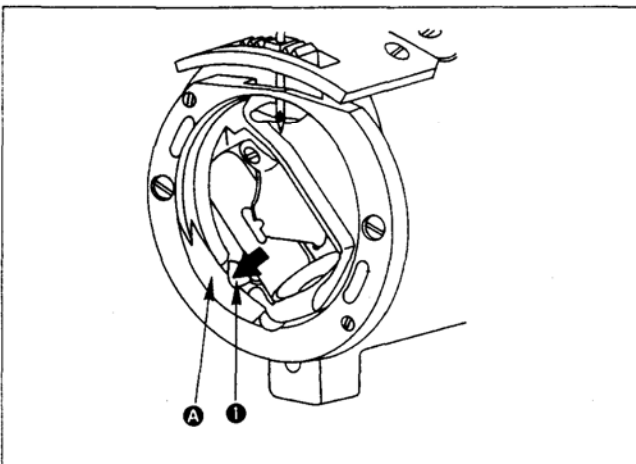

1. Turn the handwheel by hand (until the needle bar comes down to the lowest point of its stroke) so that case retaining spring ① in the shuttle body comes to recess ② in the cover of the shuttle race body.

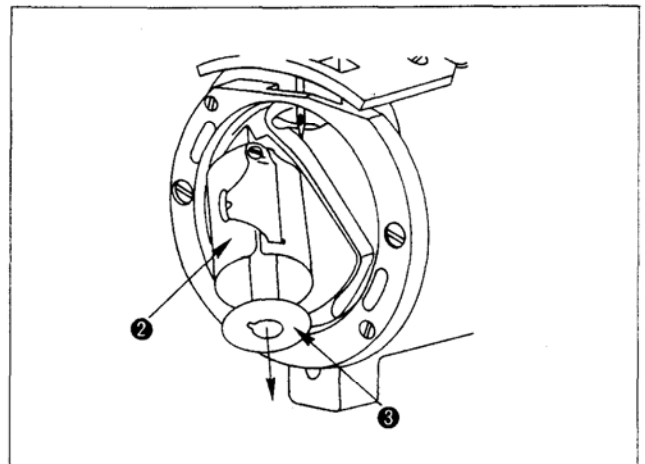

2. When the case retaining spring is pressed, the bobbin case ② will be opened and the bobbin ③ will pop out of the case.

9. HOW TO INSTALL THE BOBBIN

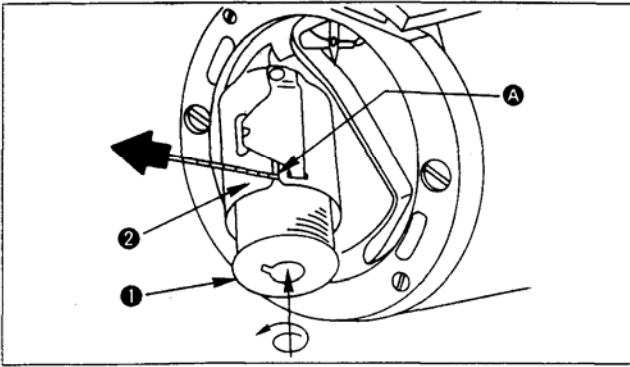

1. After pulling out thread approximately 10 cm from bobbin ①, put the bobbin into bobbin case ②.
2. Pass the thread through the threading groove ④ in the bobbin case.

(Caution) Fit the bobbin in the bobbin case so that the bobbin turns in the direction of the arrow when the bobbin thread is pulled.

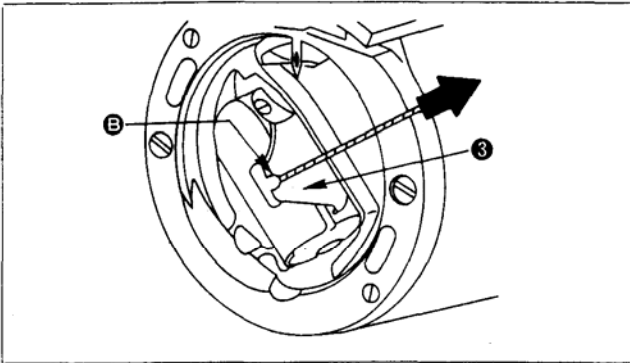

3. Pass the thread through thread slit ⑤ and pull it up. Then the thread can be passed under the thread tension spring ③ and pulled out.
4. Push the bobbin case into the original position of holding the bobbin.

10. HOW TO THREAD THE MACHINE HEAD

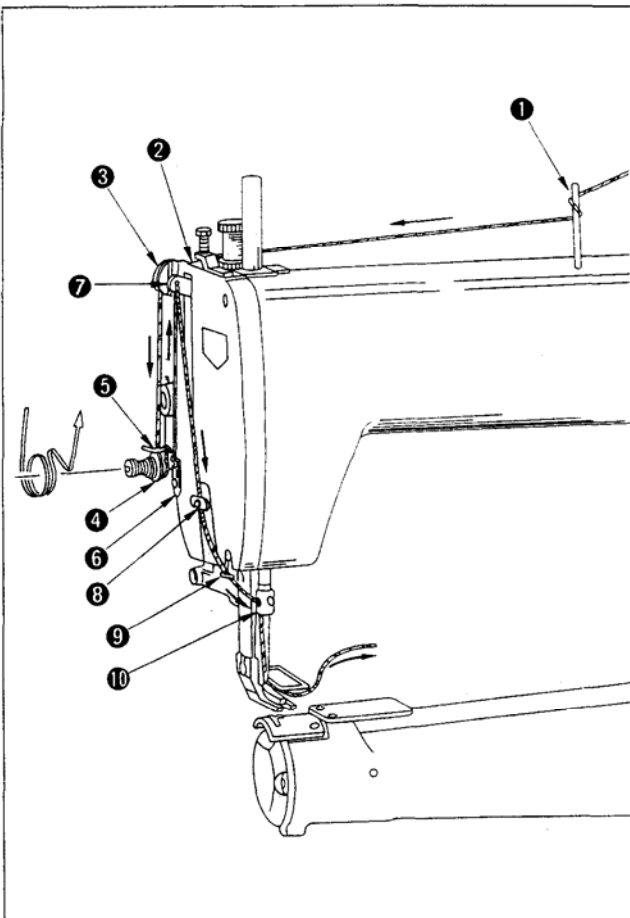

1. Turn the handwheel by hand to move the thread take-up lever to its top position.
2. Thread in the order illustrated and thread the needle from the left to the right.
3. Pull out the thread, which has been threaded in the needle, approximately 10 cm.

(Caution) Thread the right-hand side of section ⑧ when viewed from the face plate.

11. ADJUSTING THE STITCH LENGTH AND REVERSE STITCHING

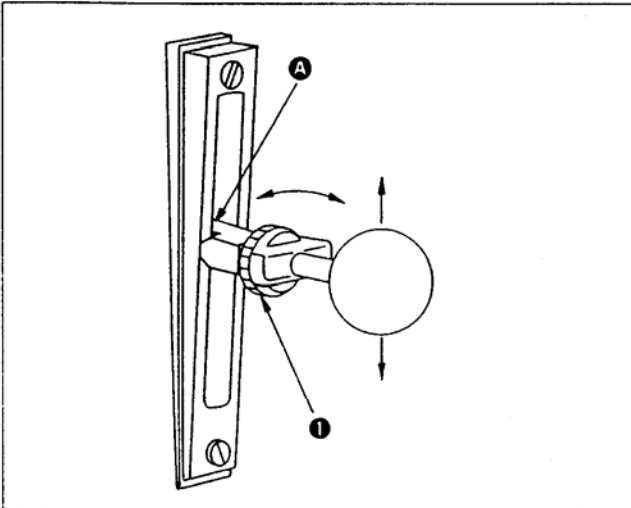

★ Adjusting the stitch length

To adjust the stitch length, use the feed regulator nut ① . Align the upper end A of the feed lever to the scale indicating the desired amount.

To increase the pitch, turn the nut counterclockwise.

To decrease the pitch, turn the nut clockwise.

(To decrease the stitch length, turn the nut while slightly pushing the feed lever down.)

★ Reverse stitching

To carry out reverse stitching, push the feed lever up by hand as far as it will go.

Reverse stitching can be done only when the feed lever is pushed up.

12. THREAD TENSION

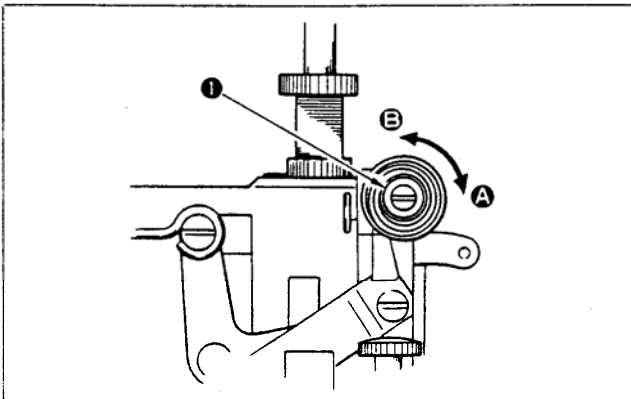

★ Adjusting the needle thread tension

Adjust the needle thread tension by thread tension nut ① .

To increase the needle thread tension, turn the nut to the clockwise A .

To decrease the needle thread tension, turn the nut to the counterclockwise B .

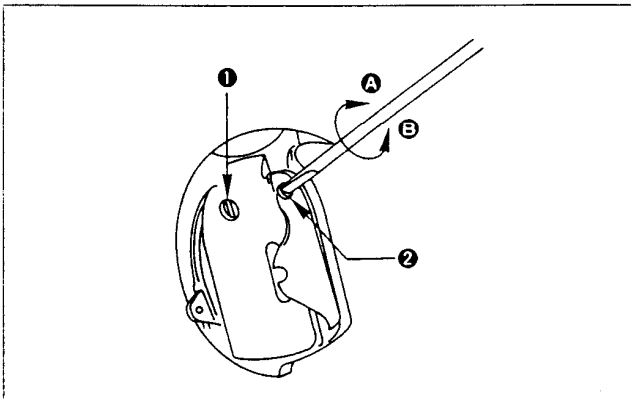

★ Adjusting the bobbin thread tension

To adjust the bobbin thread tension

1. Loosen screw ① .

2. Adjust the bobbin thread tension by turning screw ② .

To increase the bobbin thread tension, turn the screw to the clockwise A .

To decrease the bobbin thread tension, turn the screw to the counterclockwise B .

3. After the bobbin thread tension has been adjusted, tighten screw ① firmly.

13. THE THREAD TAKE-UP SPRING

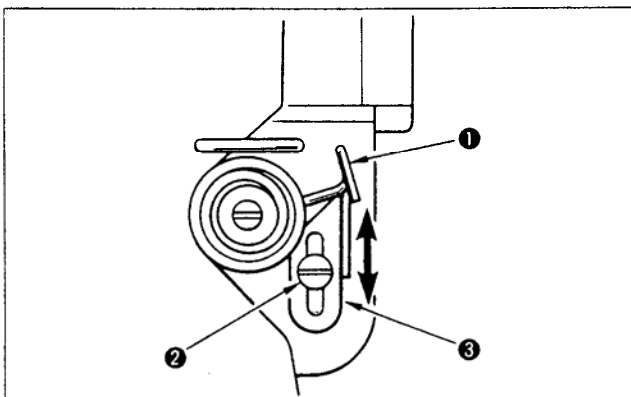

The standard stroke of thread take-up spring ① is 8 to 10 mm.

To adjust the operating range;

1. Loosen screw ② .

2. Adjust the operating range by moving the thread take-up spring adjusting plate ③ up and down.

3. After adjustment has been completed, tighten screw ② firmly.

14. ADJUSTING THE PRESSER FOOT PRESSURE

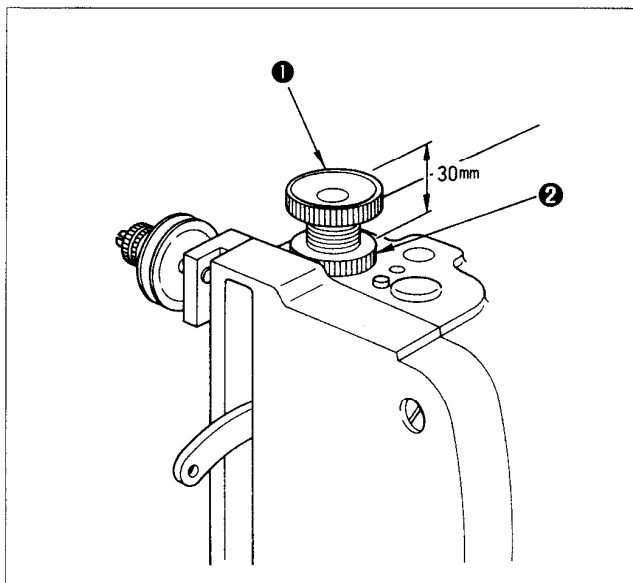

The standard height of presser spring regulator ① 30 mm above the main unit surface.

The presser foot pressure can be adjusted according to the material to be sewn.

To adjust the presser foot pressure

1. Loosen the presser spring regulator nut ②.
2. Turn the presser spring regulator ① clockwise to increase the pressure of the presser foot, or counterclockwise to decrease it.
3. After adjustment has been completed, turn the nut ② firmly, making sure to keep it securely in place.

* Use a minimum amount of required pressure.

15. ADJUSTING THE HEIGHT OF THE FEED DOG

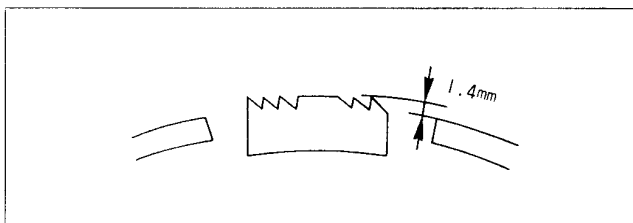

The advance amount of the feed dog from throat plate has already been adjusted to 1.4 mm.

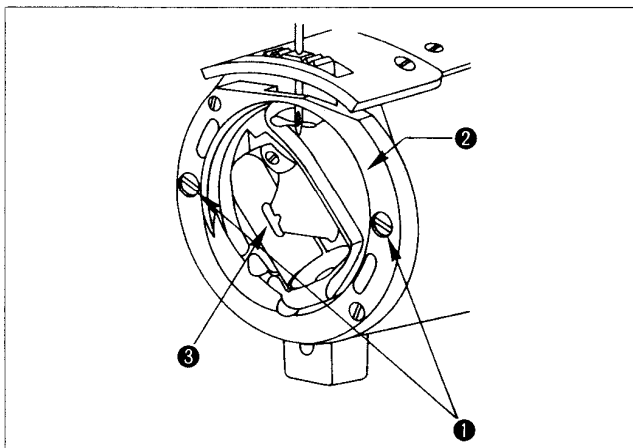

To adjust the height of the feed dog according to the sewing condition given,

1. Remove two screws ① in the shuttle race, and remove shuttle race ② . Then remove shuttle ③ .

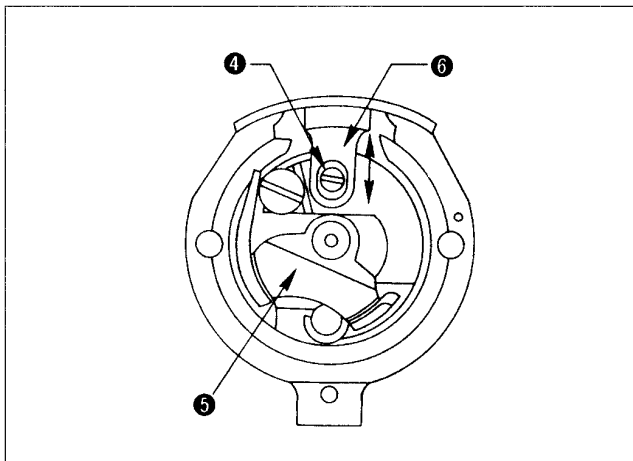

2. Turn the handwheel to move shuttle driver ⑤ until screw ④ in the feed dog appears.
3. Loosen screw ④ in the feed dog, and adjust the height of the feed dog by moving feed dog ⑥ up or down.
4. After the adjustment, firmly tighten screw ④ in the feed dog.

16. ADJUSTING THE NEEDLE-TO-SHUTTLE RELATIONSHIP

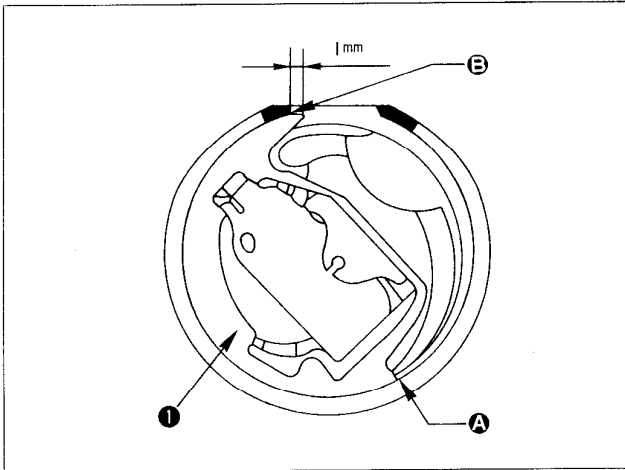

★ **The position of the shuttle when it is recessed most.**
When shuttle ① turns counterclockwise until it will go no further and the shuttle and the shuttle race come in contact with each other at point ①, a distance of 1 mm should be provided between the blade point of the shuttle and end face ② of the shuttle race.

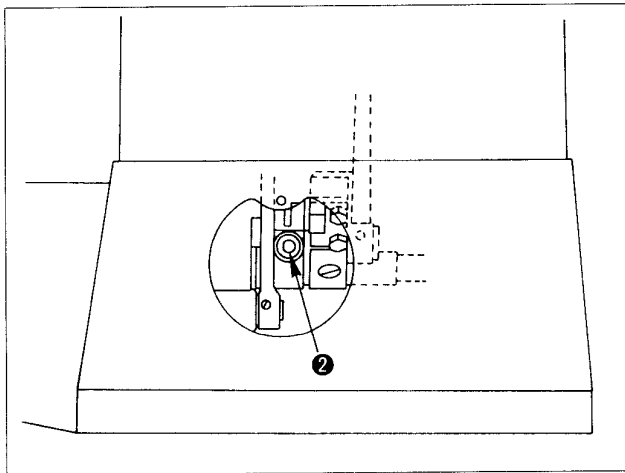

- To adjust the position of the shuttle being pulled:
1. Turn the handwheel and stop turning when the shuttle turns counterclockwise until it will go no further.
 2. Loosen screw ②.
 3. Align the blade point of the shuttle by turning the shuttle by hand.
 4. After adjustment has been completed, tighten screw ② firmly.

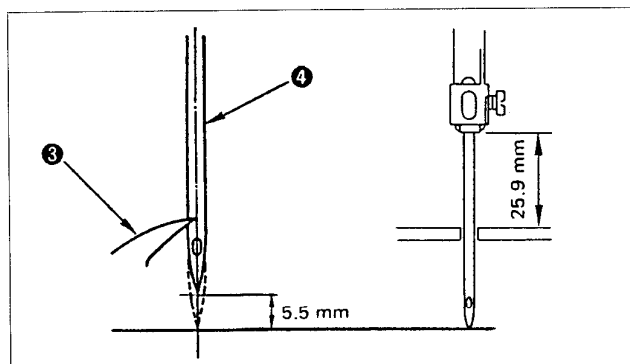

★ Positioning the needle and shuttle

Set the stitch length dial at "0".
Adjust the needle-to-hook relation so that blade point 3 of the hook is aligned with the center of needle 4 when the handwheel is turned toward you until the needle bar ascends from its lowest point by 5.5 mm.

(Reference value of the lowest position of the needle bar stroke)

The distance from the upper surface of the throat plate to the lower end of the needle bar should be 25.9 mm with the feed pitch set to 0 mm.

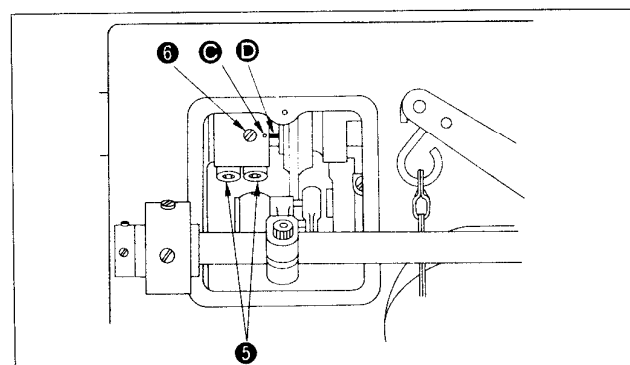

To adjust the position of the needle and shuttle

1. Loosen screw (B) ⑤.
2. Loosen screw (A) ⑥, and adjust so that marker dot ③ engraved on the eccentric cam of the vertical rod is aligned with marker line ④ engraved on the main shaft. Then, tighten screw ⑥.
3. Turn the handwheel toward you, and check the lifting amount of the needle bar.
4. After the adjustment, securely tighten screws ⑤ and ⑥.

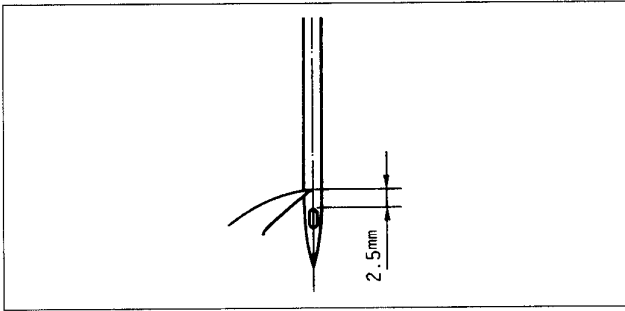

★ **The height of the needle bar**

The correct height is that the distance from the blade point of the shuttle to the upper end of the needle eyelet is 2.5 mm when the blade point of the shuttle is aligned with the center of the needle.

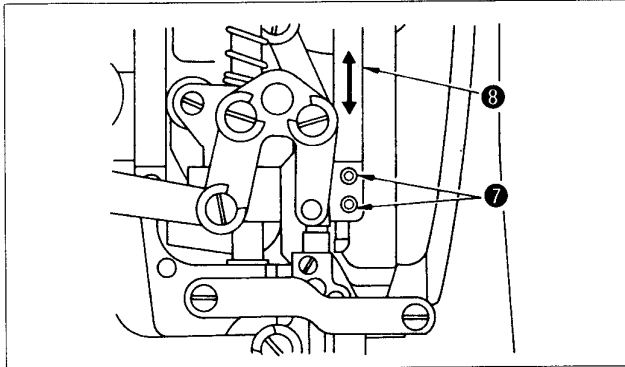

To adjust the height of the needle bar:

1. Set the stitch length dial at 0 mm.
2. Turn the handwheel and stop turning it when the blade point of the shuttle is aligned with the center of needle.
3. Loosen screws ⑦ .
4. Adjust the height by moving needle bar ⑧ up and down.
5. After adjustment has been completed, firmly tighten screws ⑦ .

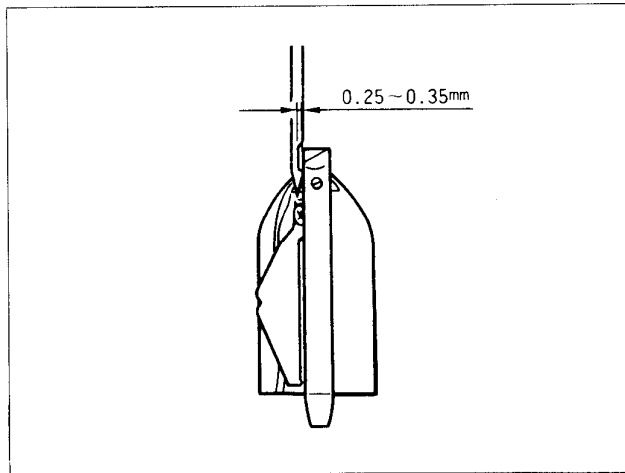

★ **The needle-to-shuttle clearance**

The clearance between the recess in the needle and the blade point of the shuttle has already been adjusted to 0.25 ~ 0.35 mm.

Point of the shuttle has already been adjusted to 0.35 mm. Adjust the clearance between the needle and the shuttle by replacing the shuttle race back.

(The shuttle race back comes in six different thickness in addition to the standard thickness.)

Thickness (mm)	Part name	Part No.	Remarks
2.9 ⁰ _{-0.03}	Shuttle race (1)	21155007	
3.1 ⁰ _{-0.03}	Shuttle race (2)	21155106	
3.3 ⁰ _{-0.03}	Shuttle race (3)	21155205	
3.5 ⁰ _{-0.03}	Shuttle race (4)	21155304	Standard
3.7 ⁰ _{-0.03}	Shuttle race (5)	21155403	
3.9 ⁰ _{-0.03}	Shuttle race (6)	21155502	
4.1 ⁰ _{-0.03}	Shuttle race (7)	21155601	

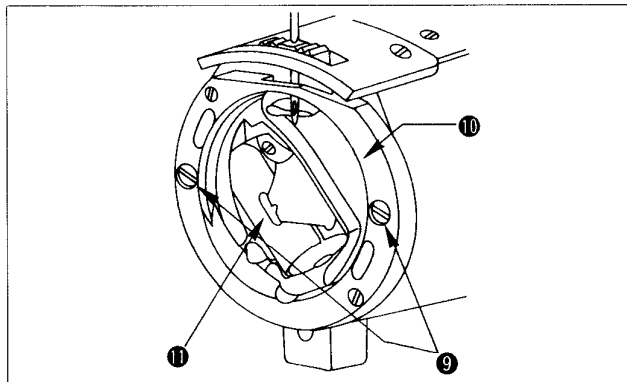

To replace the shuttle race back,

1. Remove two screws ⑨ in the shuttle race, remove shuttle race ⑩ , and remove shuttle ⑪ .

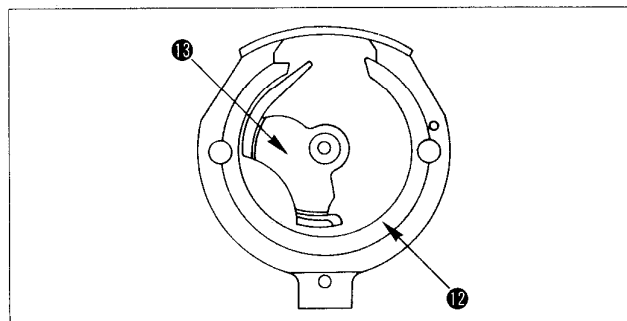

2. Turn the handwheel until shuttle driver ⑬ is brought to the position where shuttle race back ⑫ comes off. Then replace the shuttle race back.

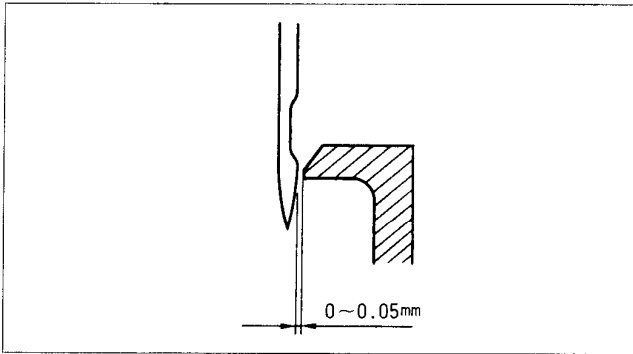

★ **Clearance between the needle and the shuttle driver**
 The clearance between the needle and the needle guide of the shuttle driver has already been adjusted to the range of 0 through 0.05 mm.

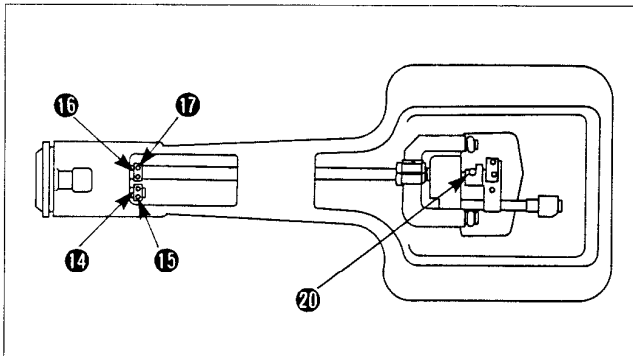

To adjust the clearance between the needle and the shuttle driver:

1. Loosen two screws 15, and remove thrust collar 14 of the feed rock driving shaft on the feed bracket.
2. Loosen two screws 17, and move thrust collar 16 of the feed rock shaft.
3. Loosen two screws 18 in the shuttle driving shaft thrust collar, screw 19 in the shuttle driving shaft front bushing and small pendulum clamping screw 20

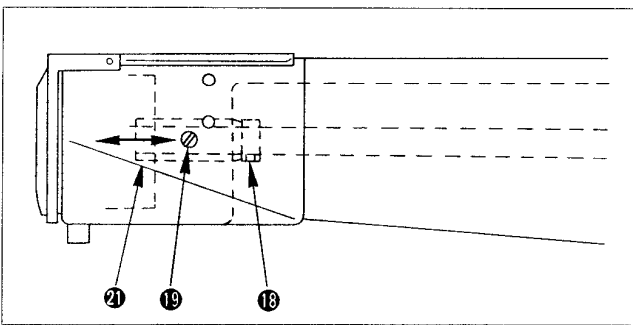

4. Adjust the clearance by moving shuttle driving shaft front bushing 21 to the left and right.
5. After the adjustment, fix the thrust collar of the hook driving shaft elimination an axial play in the hook driving shaft. Then fix the small pendulum in place.
6. Finally, secure the respective thrust collars, making sure there is no play in the feed driving shaft and the feed rock shaft.

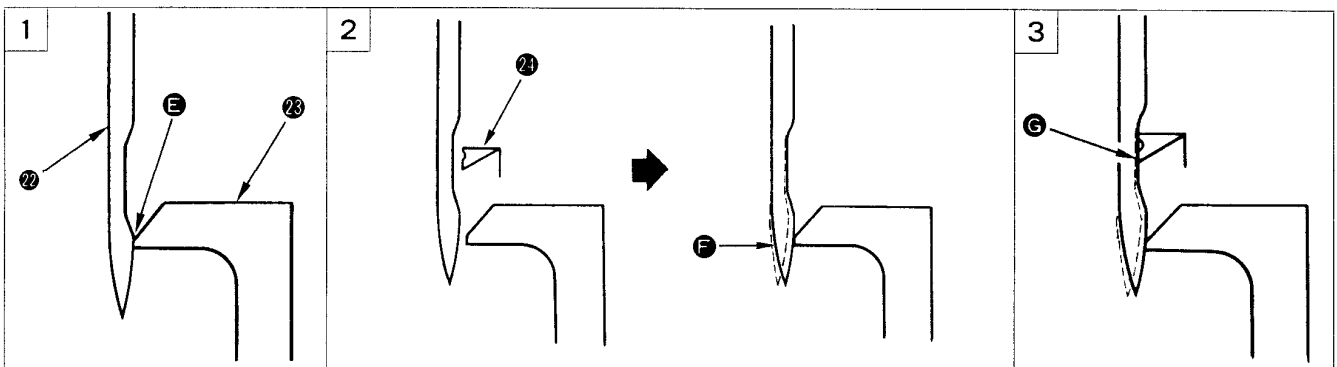

[The standard for adjusting the clearance between the needle and the blade point of the shuttle]

Use a standard Schmetz 794-Nm230 needle.

1. Adjust the clearance E between the convex section of needle 22 and shuttle driver 23 to 0.
2. Align the needle center with the blade point of shuttle 24 and press the F section of the needle against the shuttle driver.
3. Adjust the clearance G to a minimum, with the needle pressed against the shuttle driver, making sure that the needle does not contact the blade point of the shuttle.

* By this adjustment the needle-to-shuttle blade point clearance will be 0.25 ~ 0.35 mm.

17. ADJUSTING THE WALKING FOOT AND THE PRESSER FOOT

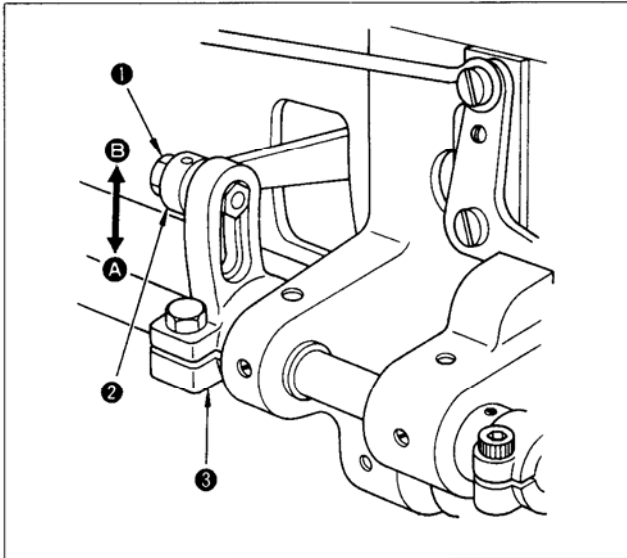

★ Operating height of the walking foot and the presser foot

The standard operating height has been minimized. The operating height may be changed for better finish according to the sewing product.

1. Loosen hinged screw ① in the walking foot rod.
2. Secure walking foot rod ② to lower area A of the slot in the walking foot arm (rear) ③ to maximize the operating height (8 mm), or to upper area B to minimize the operating height (4 mm).
3. After the adjustment, firmly tighten hinge screw ① in the walking foot rod.

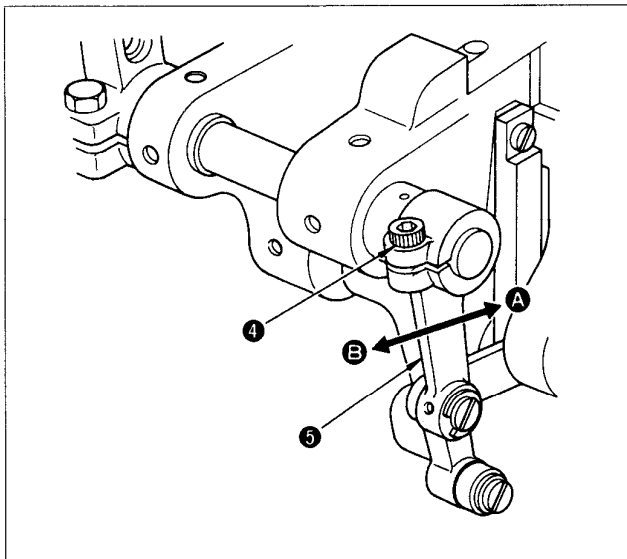

★ The amount of alternating vertical movement of the walking foot and the presser foot

Vertical movement of the walking foot and that of the presser foot are actuated alternately. For standard adjustment, the amount of vertical movement of the walking foot should be equal with that of the presser foot. However, the amount vertical movement of the walking foot is desired to be slightly decreased in accordance with the type of material to be sewn. This may result in better-finished products.

1. Bring the thread take-up to the lowest position of its stroke, and lower the presser foot.
2. Loosen screw ④.
3. Move walking foot arm (front) ⑤ to right A to increase the moving amount of the walking foot. Move the walking foot arm (front) ⑤ to the left B and movements will be equal.
4. After the adjustment, firmly tighten clamping screw ④ in the walking foot arm (front).

18. THE FEED DOG-TO-NEEDLE RELATIONSHIP

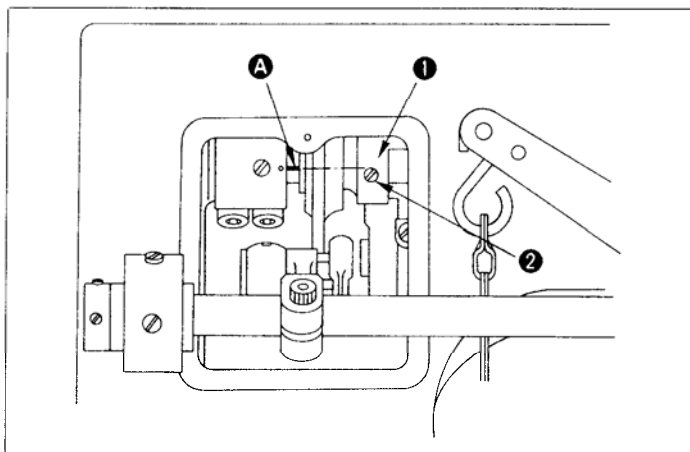

As standard timing of the feed dog, when the center of the needle aligns with the blade point of the shuttle with the feed pitch set to "0", the feed dog should move from right to left by 1 mm when observed from the face plate by moving the feed lever from the position to set the normal feed pitch to the maximum value to the position to set the reverse feed pitch to the maximum value.

★ To adjust the timing:

1. Loosen the two screws for the feed eccentric cam ①.
2. Adjust the timing to the standard one by aligning the top end of screw No. 1 ② in the feed eccentric cam with marker line A engraved on the main shaft.
3. After adjusting the timing has been completed, firmly tighten the two screws for the feed eccentric cam.

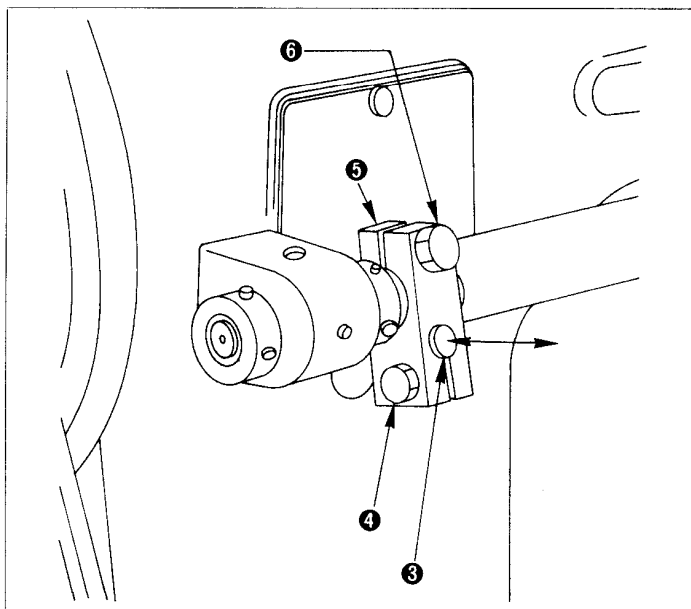

★ The motion of the feed dog and needle

The center of the needle hole in the feed dog must move with synchronized completely with the needle.

< How to adjust the needle sway >

If there is any lag in the motion of the feed dog and that of the needle, and the needle entry at the sewing end is not same as that at the sewing start, perform the following adjustment.

1. Loosen clamping screw ④ in center shaft rear arm (B) ③.
2. Move center shaft rear arm (B) ③ toward/away from you and temporarily tighten the screw. At this time, move center shaft rear arm (B) ③ away from you to decrease the oscillating width of the needle bar frame, or pull the arm (B) toward you to increase it.
3. Slowly turn the handwheel by hand to confirm that there is no lag between the motion of the feed dog and that of the needle.
4. Repeat the above stated steps until the feed dog and the needle move with completely synchronized.
5. After the adjustment, firmly tighten screw ④.

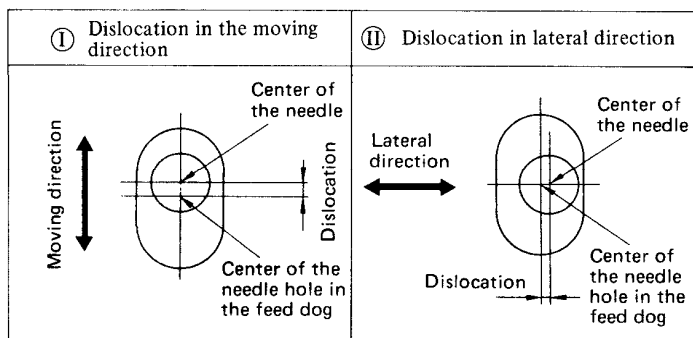

★ Needle entry point with respect to the needle hole in the feed dog

If the needle fails to enter just the center of the needle hole in the feed dog even when the motions of the feed dog and the needle are completely synchronized.

1. Check whether the needle is bent.
2. Check the direction of the dislocation either ① or ② as illustrated in the figure.

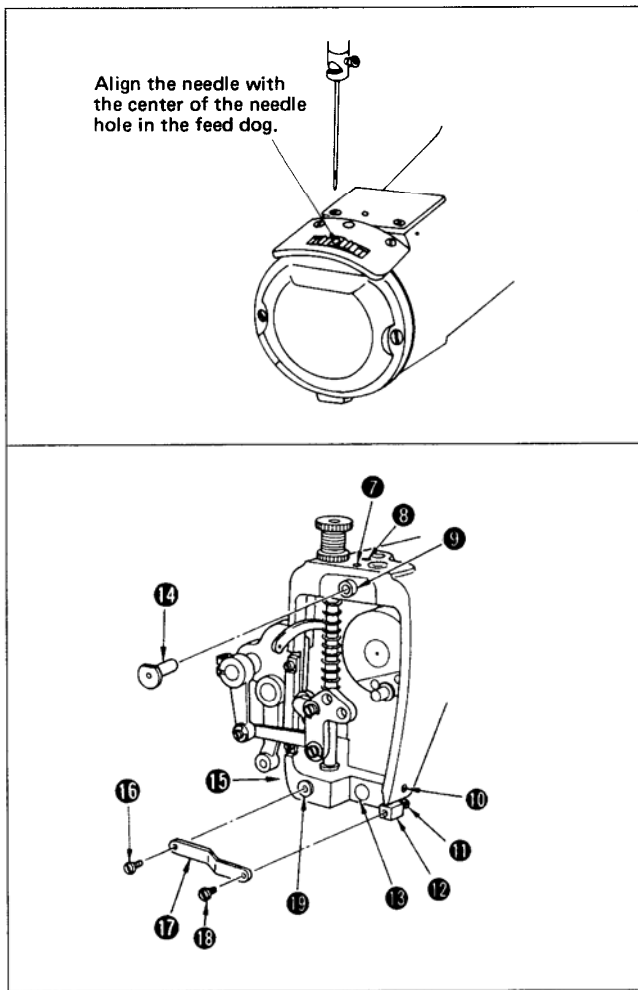

★ **Adjusting the needle entry point**

I When the needle entry point dislocates in the moving direction.

1. Loosen clamping screw ⑥ in center shaft rear A ⑤ .
2. Align the needle with the center of the needle hole in the feed dog.
3. After the adjustment, firmly tighten the screw.

II When the needle entry points dislocates in the lateral direction.

1. Remove the screw in the face plate, and remove the face plate.
2. Remove screws ⑮ and ⑯ , and remove needle bar frame presser plate ⑰ .
3. Loosen screw ⑩ to allow needle bar frame guide ⑬ to move freely.
4. Loosen screws ⑦ and ⑧ , and move needle bar frame shaft bushing ⑨ until the needle is aligned with the center of the needle hole in the feed dog.
5. Loosen screw ⑦ , and retain needle bar frame shaft bushing ⑨ so that it does not move.
Tighten screw ⑧ when the play in the needle bar frame is minimized so that needle bar frame shaft ⑭ is secured at that position.
6. Make needle bar frame guide ⑬ come in slight contact with the needle bar frame, and fix the guide at that position by tightening screw ⑩ .
7. Loosen screws ⑪ and ⑮ , and position needle bar frame presser retaining shaft ⑲ and needle bar frame presser retaining plate ⑫ to the position where the needle bar frame moves smoothly without play when needle bar frame presser plate ⑰ is attached to the needle bar frame. Then tighten the screws.

(Caution) After the needle entry point has been adjusted, be sure to confirm the clearance between the needle and the blade point of the shuttle as well as the clearance between the needle and the finger.

19. THE MOTOR PULLEY AND THE V BELT

Sewing speed of the machine (s.p.m.)	4P			
	50 Hz		60 Hz	
	Motor pulley O.D.	Belt length	Motor pulley O.D.	Belt length
600	65 mm	55 inches	55 mm	54 inches
800	85 mm	56 inches	70 mm	55 inches

1. Use an M-type motor pulley and V belt.
2. The relationship between the motor pulley/belt length and the sewing speed of the machine is shown in the table on the right.

(Caution) When using a single phase motor, use belts of 1 inch longer than those shown in the right-hand table.

20. PROBLEMS WITH SEWING AND CORRECTIVE MEASURES

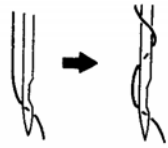
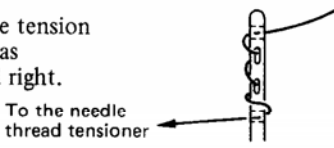
Problem	Cause	Corrective measures
1. Thread often breaks or thread splits finely, correct stitch cannot be formed (half-finished stitch)	<ul style="list-style-type: none"> ① Flaw is found out at thread path, needle point, shuttle blade point, or needle eyelet. ② Improper finish around the recess in the needle. ③ Excessively tightened needle thread tension ④ The needle interferes with the blade point of the shuttle. ⑤ The timing of the needle and the shuttle is too early or too slow. ⑥ Due to heat generated by the needle. ⑦ Excessive height difference at stepped section. 	<ul style="list-style-type: none"> ○ Remove flaw by smoothing flaw with fine paper file. ○ Replace the needle with a new one. ○ Adjust the needle thread tension. ○ Refer to "17. Adjusting the needle-to-shuttle relationship". ○ Refer to "17. Adjusting the needle-to-shuttle relationship". ○ Decrease the sewing speed of the machine. Use silicone oil. ○ Increase the amount of movement of the thread take-up spring.
2. Stitches are frequently skipped	<ul style="list-style-type: none"> 1. The needle-to-shuttle blade point clearance is excessive. 2. The timing of the needle and the shuttle is too early or too slow. 3. The presser bar pressure is insufficient. 4. The distance from the upper end of the needle eyelet to the blade point of the shuttle is not proper. 5. The needle is improperly selected. 6. The amount of movement of the thread take-up spring is excessive. 7. Overheated needle or shuttle. Thread is not pulled smoothly. 8. Reverse stitching is made at low speed on light weight material using nylon thread. 	<ul style="list-style-type: none"> ○ Refer to "17. Adjusting the needle-to-shuttle relationship". ○ Refer to "17. Adjusting the needle-to-shuttle relationship". ○ Tighten the presser adjuster screw. ○ Refer to "17. Adjusting the needle-to-shuttle relationship". ○ Replace the needle with a one-count lower needle. ○ Decrease the amount of movement of the thread take-up spring. ○ Use silicone oil. ○ Wind the needle thread around the needle. <div style="text-align: center; margin-top: 10px;">  </div>
3. Improper thread tension, irregular stitch, excessive bobbin thread tension	<ul style="list-style-type: none"> ① The needle hole in the walking foot, needle hole in the feed dog or thread path in the thread guides has scratches. ② The bobbin slides unsmoothly. ③ Weak bobbin thread tension. ④ Bobbin thread is wound too tightly. ⑤ Needle thread flaps. (Needle thread flaps and comes out of the thread tension disc due to excessive needle thread tension or is caught in other parts.) ⑥ Too thin bobbin thread is used to combine with needle thread. 	<ul style="list-style-type: none"> ○ Smooth the surface with a fine paper file or using a buff. ○ Replace the bobbin or the shuttle. ○ Adjust the bobbin thread tension. ○ Decrease the tension of the bobbin thread winder. ○ Thread the tension guide bar as illustrated right. ○ Use silicone oil. <div style="text-align: center; margin-top: 10px;">  </div>
4. Poor gloss of the needle thread	<ul style="list-style-type: none"> ○ Excessive height difference at stepped section. 	<ul style="list-style-type: none"> ○ Use silicone oil.

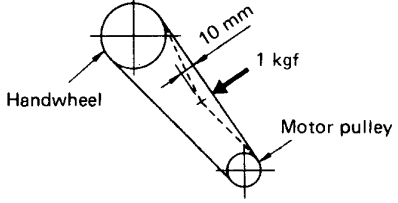
Problem	Cause	Corrective measures
5. Inconsistently finished seam (stitches are not made straight but made such as “ ≡ ”)	○ Needle is too thick.	○ Replace the needle with a thinner one. Use cutting point needle 
6. Bobbin thread tension cannot be increased.	○ The bobbin thread tension spring of the shuttle has become dusty or dirty.	○ Clean by removing the bobbin thread tension spring.
7. The belt slips (Motor stoppage occurs, if an electronic-stop motor is used.)	① The V belt is degraded. ② The V belt tension is not enough.	○ When degradation is found out to the V belt, such as wear, cracking, etc., replace with a new one. ○ Adjust the slack amount in the V belt to 10 mm/1 kgf. 

Distributor: