

MODEL: CK-243

SINGLE NEEDLE, UNISON-FEED, LOCKSTITCH SEWING

MACHINE FOR EXTRA HEAVY-WEIGHT MATERIALS

單針極厚綜合送料縫紉機

INSTRUCTION MANUAL

操作手冊



Chikon Industrial Sewing Machine Co., Ltd.

2011-07

Please read this instruction manual carefully before using the unit in order to get the most out of it and to enjoy using it for a long time.

BEFORE OPERATION

1. Do not run the machine even for trial before lubricating it.
2. Confirm that the voltage and phase (single- or 3-phase) are correct by checking them against the ratings shown on the motor nameplate.
3. When running your machine for the first time after the set-up, check the rotational direction of the handwheel.
 - Turn ON the power switch. Run the machine at a low speed while checking the rotational direction of the handwheel. (The handwheel should turn counterclockwise as observed from the handwheel side.)
4. For the first month, run the machine at a speed of 600 s.p.m. or less.

CAUTIONS IN OPERATION

1. Keep your hands away from the needle when you turn ON the power switch or while the machine is operating.
2. During operation, be careful not to allow your or any other person's head or fingers to come close to the handwheel, V belt, bobbin winder or motor. Also, do not place anything close to them.
3. Do not run the machine with the finger guard, belt cover or any other protectors removed.
Eye guard is option
4. Be sure to turn OFF the power switch and confirm that the motor is completely stopped before removing the V belt.
5. Never remove the sewing machine from the table with the motor removed from the table.

SPECIFICATIONS

Usage	Pouches, bags, shoes, bag handles, safety belts, etc.	Needle to be used	Schmetz 794 Nm230
		Needle system	Nm130 ~ Nm280
Sewing speed	Max. 800 s.p.m.	Thread	#00 ~ #8
Stitch length	Max. 15 mm	Stitch adjusting method	Lever nut type
Lift of presser foot	Hand lifter	12 mm,	Lubrication method
	Knee lifter	20 mm	
Thread take-up lever	Cam-type thread take-up lever	Motor to be used	3-phase/single phase 400W clutch motor (4P)
Needle bar stroke	56 mm	Oil to be used	New Defrix Oil No. 1

1. INSTALLING THE THREAD STAND

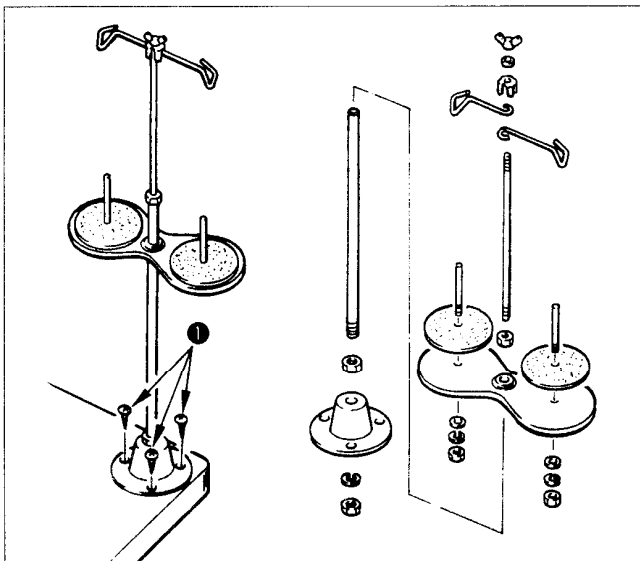

Assemble the thread stand, and install it to the right-hand side of the far side of the table with screws ① (at 3 places).

2. INSTALLING THE HANDWHEEL

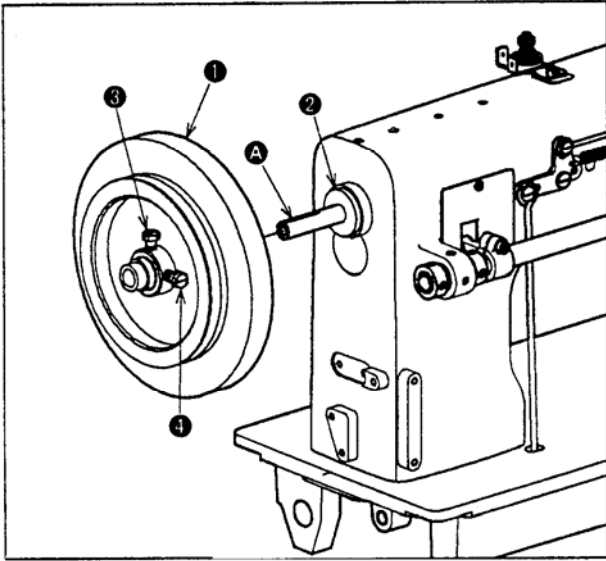

1. Fit handwheel ① close to the main shaft bushing, rear ② .
2. Align the handwheel with thread groove A in the main shaft. Tighten the first screw ③ of the handwheel, then tighten screw ④ .

3. INSTALLING THE BELT COVER

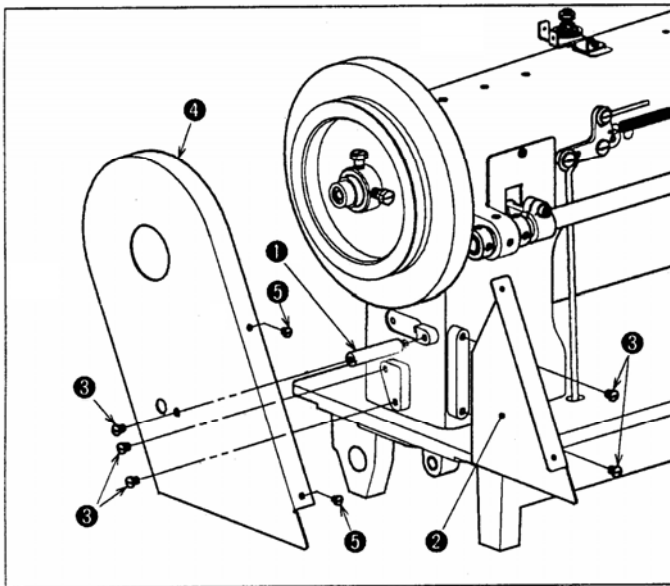

1. Install belt cover supports ① to the machine arm.
2. Install belt cover B ② to the machine arm using screws ③ .
3. Install belt cover A ④ to the machine arm using screws ③ .
4. Fix belt cover A ④ on the belt cover B ② and belt cover supports ① using screws ③ and ⑤ .

4. CLEANING

Waste thread, dust, dirt, etc., build-up around the feed dog or the shuttle may cause malfunction of the machine.

Clean periodically according to your frequency of use.

1. Clean around the feed dog after removing the throat plate.
2. Clean the inside of the shuttle race body by taking out the shuttle body after removing the cover of the shuttle race body.

5. LUBRICATION

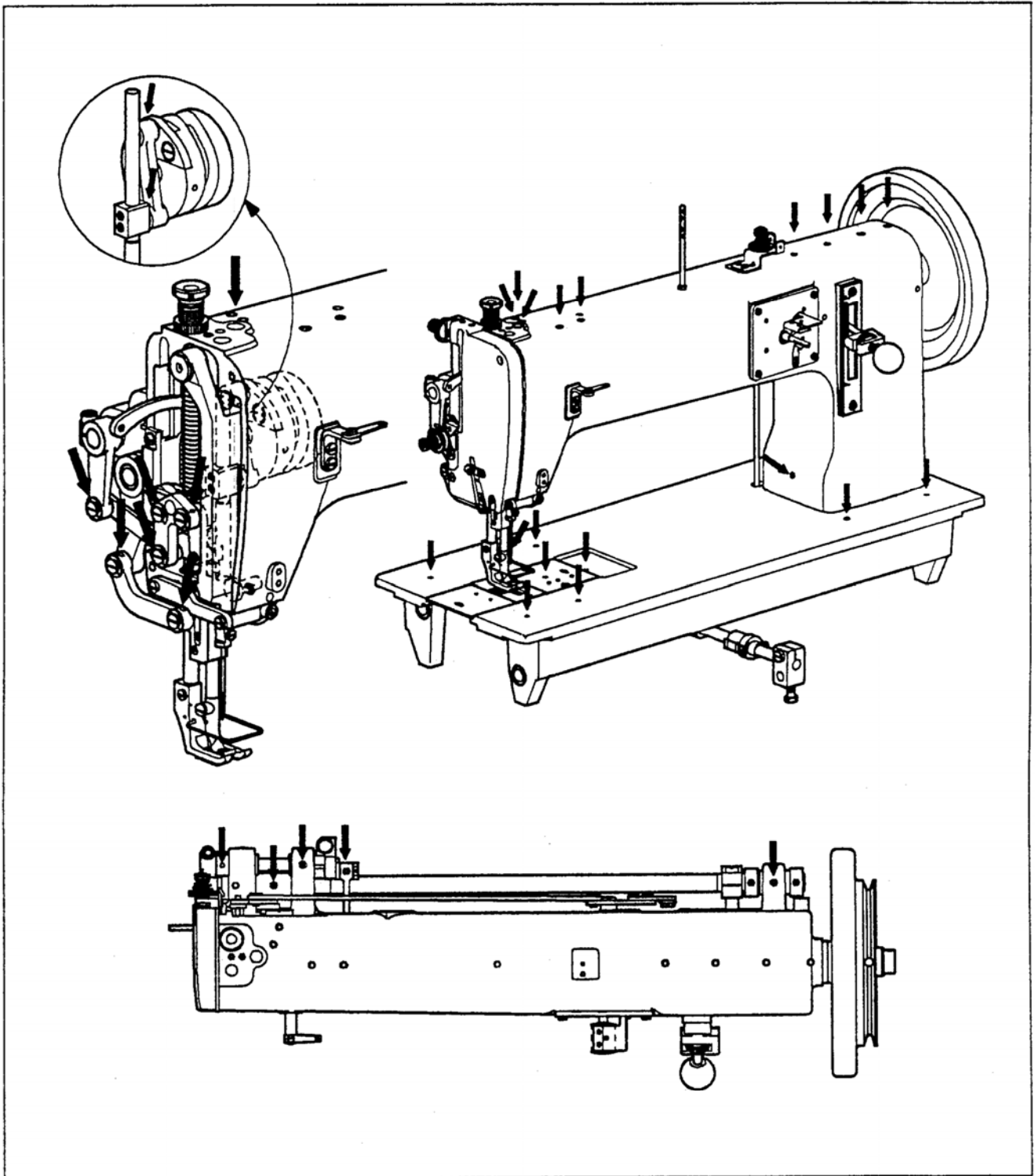

1. After uncrating, supply oil to the machine after cleaning it thoroughly.
2. When oiling all the sections requiring lubrication, after installation of the machine has been completed, wait for a while (approximately 10 minutes) so that oil can penetrate each section sufficiently before starting continuous operation.
3. To operate the machine continuously, apply two to three drops of oil to each section noted with an arrow mark in the following figure whenever starting operation in the morning and in the afternoon.

6. HOW TO INSTALL THE NEEDLE

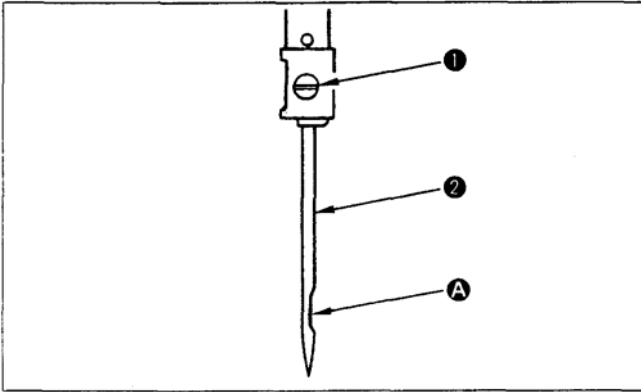

★ **Be sure to power-off the motor.**

The standard needle is a Schmetz 794, however an Organ DY x 3 can be used.

1. Turn the handwheel by hand and raise the needle bar to its top position.
2. Loosen screw ① and insert the needle ② into the hole until it will go no further.
(Insert the needle with its recess A facing directly to the right-hand side.)
3. Securely tighten the screw in the needle.

7. HOW TO TAKE OUT THE BOBBIN

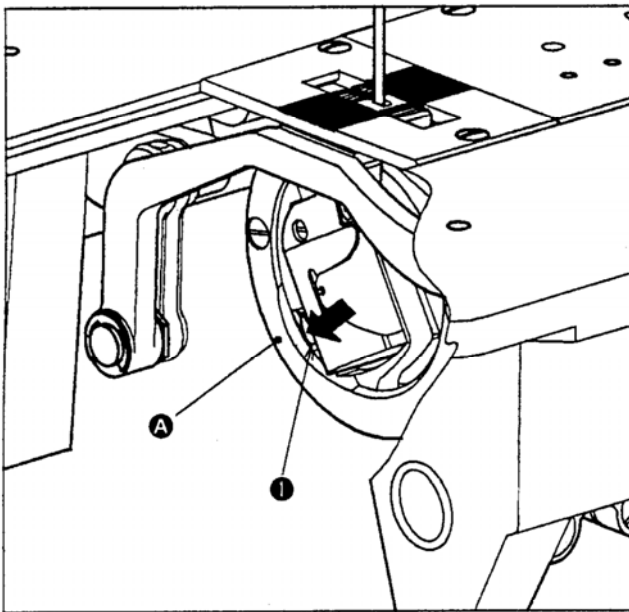

1. Turn the handwheel by hand (until the needle bar comes down to the lowest point of its stroke) so that case retaining spring ① in the shuttle body comes to recess A in the cover of the shuttle race body.

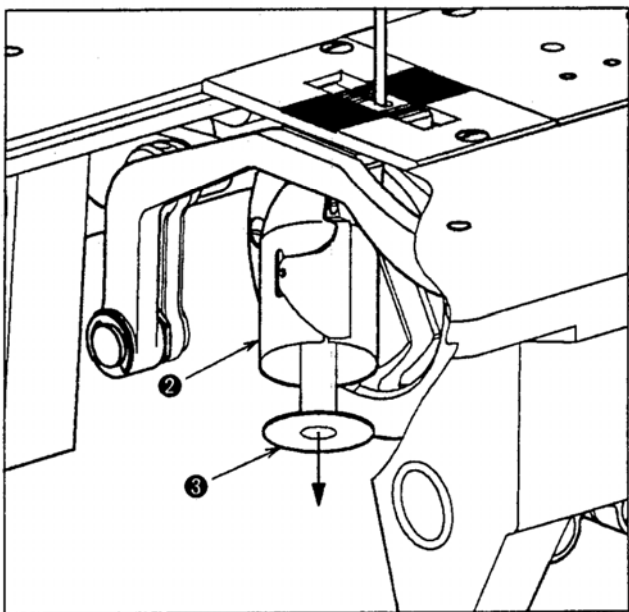

2. When the case retaining spring is pressed, the bobbin case ② will be opened and the bobbin ③ will pop out of the case.

8. HOW TO WIND A BOBBIN THREAD

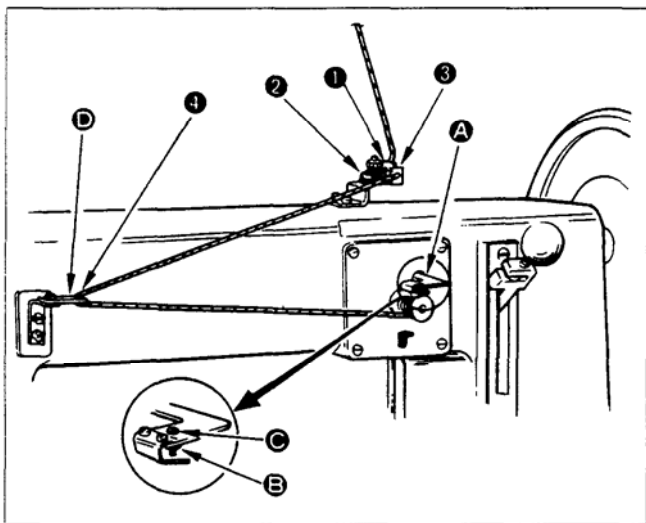

1. Raise the presser foot by the hand lifter lever.
2. Insert the bobbin into the bobbin winder spindle.
3. Thread the winder in the order illustrated and wind the thread onto the bobbin four or five turns.
4. Push the bobbin winder trip latch **A** down and the bobbin starts rotating to wind bobbin thread with the machine operated.
5. When winding of bobbin thread has been completed, the bobbin winder trip latch will be disengaged and the bobbin will stop automatically.

★ Adjusting the amount of thread wound round the bobbin

That amount of thread has already been adjusted so that thread can be wound round approximately nine-tenths of the bobbin. If the amount is excessive or insufficient, adjust:

1. by loosening the adjusting screw and nut **E**.
2. by turning the adjusting screw **C**.
To decrease the amount, turn clockwise.
To increase the amount, turn counterclockwise.
3. After adjusting the amount of thread has been completed, tighten the nut to secure firmly.

★ If bobbin thread is wound unevenly, move the bobbin winder thread guide **D** forward and backward so that thread can be wound evenly.

9. HOW TO INSTALL THE BOBBIN

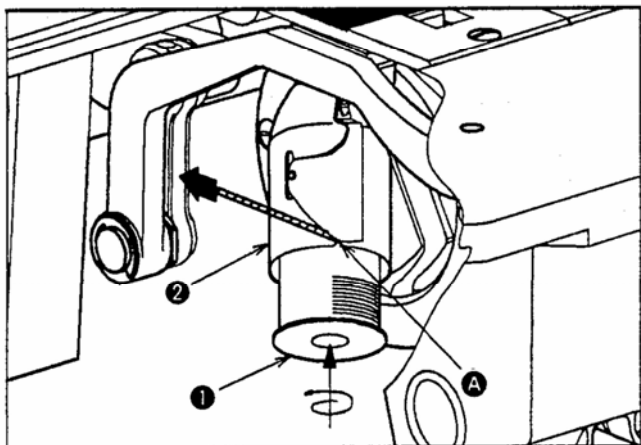

1. After pulling out thread approximately 10 cm from bobbin **1**, put the bobbin into bobbin case **2**.
2. Pass the thread through the threading groove **A** in the bobbin case.

(Caution) Fit the bobbin in the bobbin case so that the bobbin turns in the direction of the arrow when the bobbin thread is pulled.

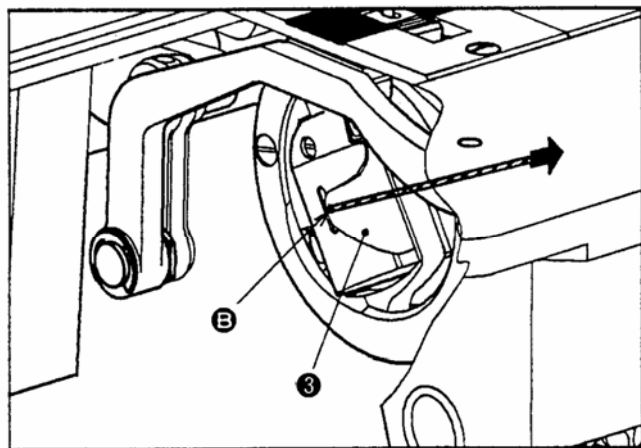

3. Pass the thread through thread slit **B** and pull it up. Then the thread can be passed under the thread tension spring **3** and pulled out.
4. Push the bobbin case into the original position of holding the bobbin.

10. HOW TO THREAD THE MACHINE HEAD

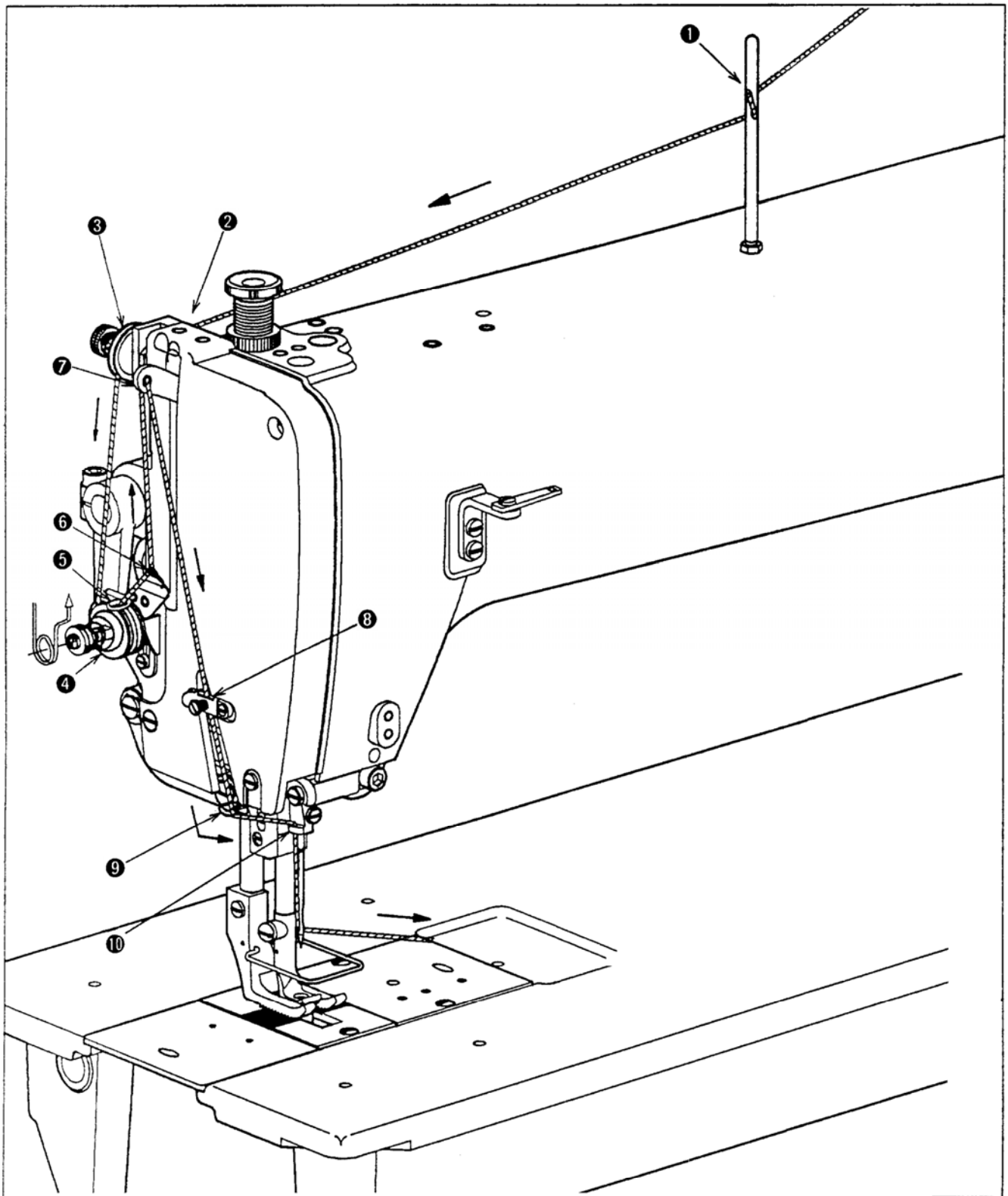

1. Turn the handwheel by hand to move the thread take-up lever to its top position.
 2. Thread in the order illustrated and thread the needle from the left to the right.
 3. Pull out the thread, which has been threaded in the needle, approximately 10 cm.
- (Caution)** Thread the right-hand side of section ⑧ when viewed from the face plate.

11. ADJUSTING THE STITCH LENGTH AND REVERSE STITCHING

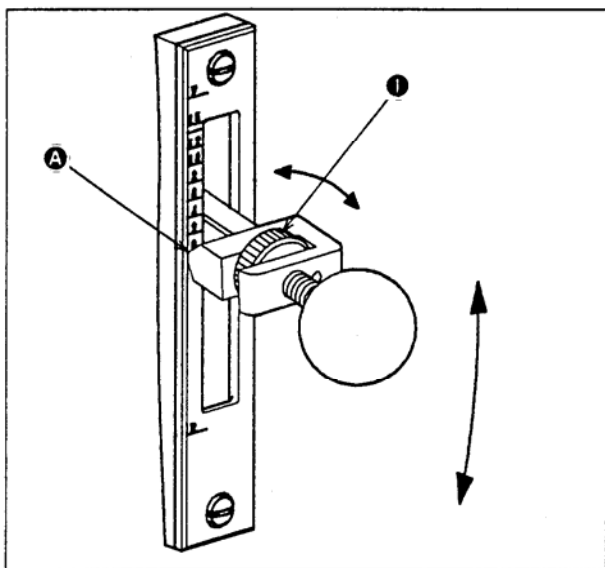

★ Adjusting the stitch length

To adjust the stitch length, use the feed regulator nut ①. Align the upper end ① of the feed lever to the scale indicating the desired amount.

To increase the pitch, turn the nut counterclockwise.

To decrease the pitch, turn the nut clockwise.

(To decrease the stitch length, turn the nut while slightly pushing the feed lever down.)

★ Reverse stitching

To carry out reverse stitching, push the feed lever down by hand as far as it will go.

Reverse stitching can be done only when the feed lever is pushed down.

12. THREAD TENSION

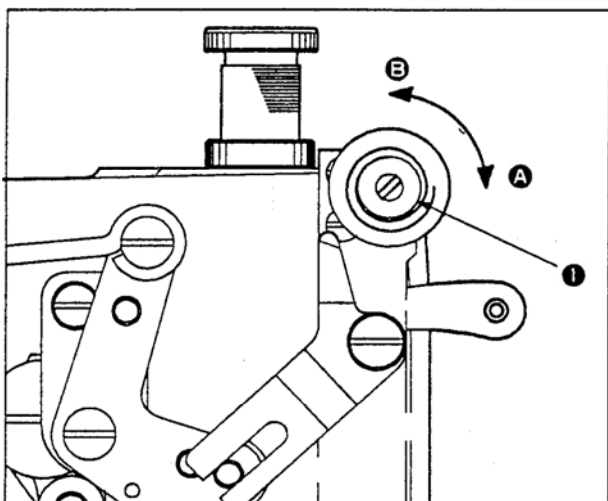

★ Adjusting the needle thread tension

Adjust the needle thread tension by thread tension nut ①.

To increase the needle thread tension, turn the nut to the clockwise ①.

To decrease the needle thread tension, turn the nut to the counterclockwise ②.

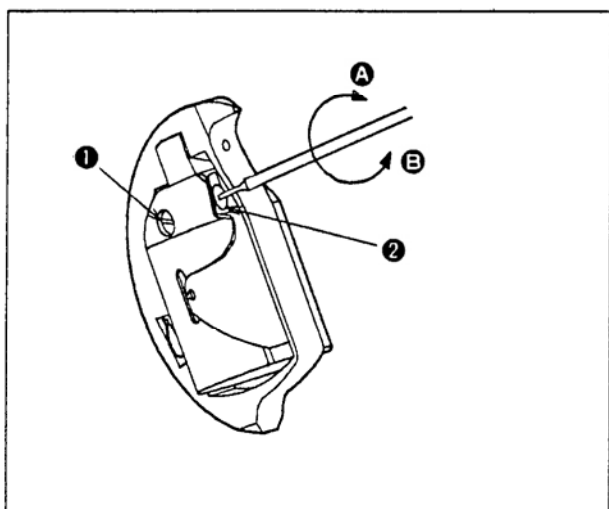

★ Adjusting the bobbin thread tension

To adjust the bobbin thread tension

1. Loosen screw ①.

2. Adjust the bobbin thread tension by turning screw ②.

To increase the bobbin thread tension, turn the screw to the clockwise ①.

To decrease the bobbin thread tension, turn the screw to the counterclockwise ②.

3. After the bobbin thread tension has been adjusted, tighten screw ① firmly.

13. THE THREAD TAKE-UP SPRING

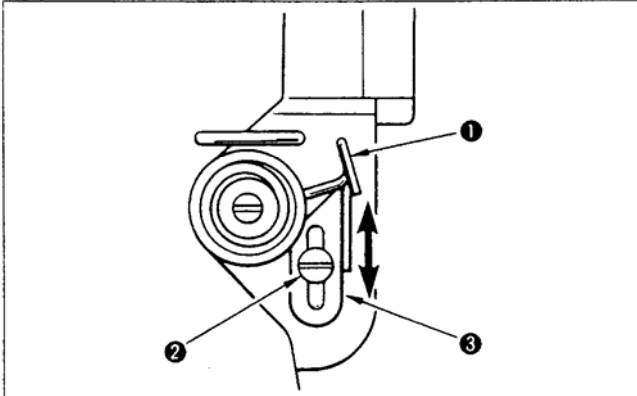

The standard stroke of thread take-up spring ① is 8 to 10 mm.

To adjust the operating range;

1. Loosen screw ② .
2. Adjust the operating range by moving thread the take-up spring adjusting plate ③ up and down.
3. After adjustment has been completed, tighten screw ② firmly.

14. ADJUSTING THE PRESSER FOOT PRESSURE

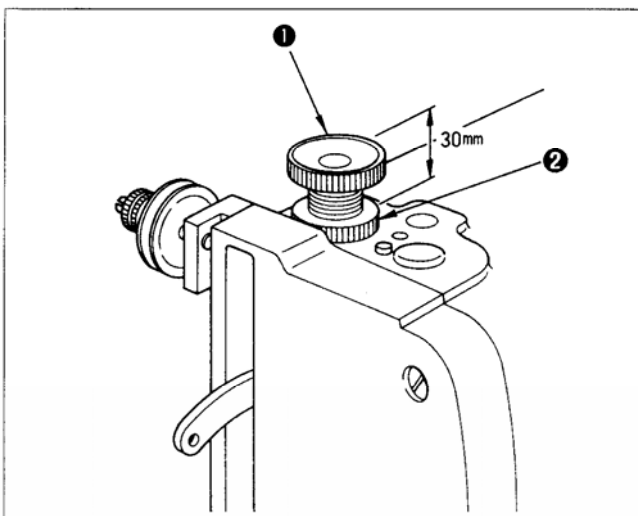

The standard height of presser spring regulator ① 30 mm above the main unit surface.

The presser foot pressure can be adjusted according to the material to be sewn.

To adjust the presser foot pressure

1. Loosen the presser spring regulator nut ②.
2. Turn the presser spring regulator ① clockwise to increase the pressure of the presser foot, or counterclockwise to decrease it.
3. After adjustment has been completed, turn the nut ② firmly, making sure to keep it securely in place.

* Use a minimum amount of required pressure.

15. ADJUSTING THE HEIGHT OF THE FEED DOG

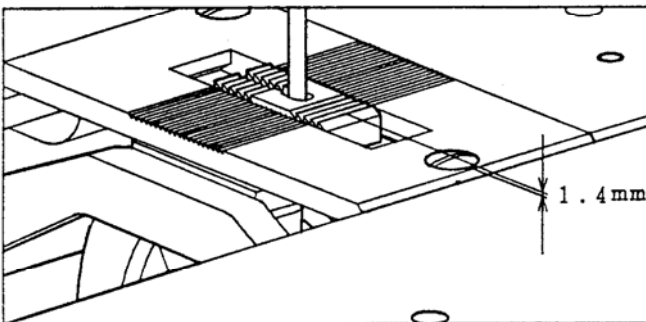

The advance amount of the feed dog from throat plate has already been adjusted to 1.4 mm.

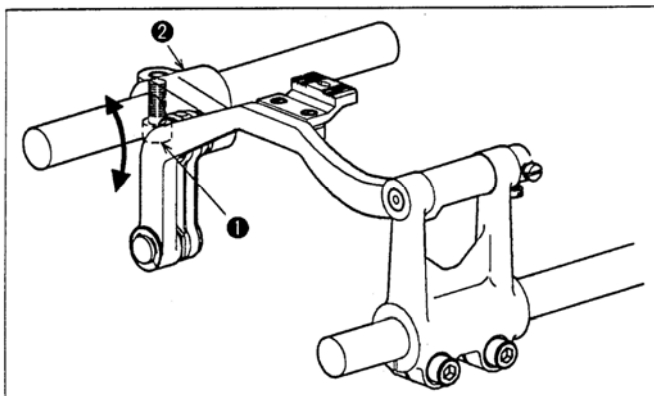

To adjust the height of the feed dog according to the sewing condition given,

1. Loosen screw ① in the feed lifting rock link ② and adjust the height of the feed dog by moving feed lifting rock link ② up and down.
2. After the adjustment, firmly tighten screw ① in the feed lifting rock link.

16. ADJUSTING THE WALKING FOOT AND THE PRESSER FOOT

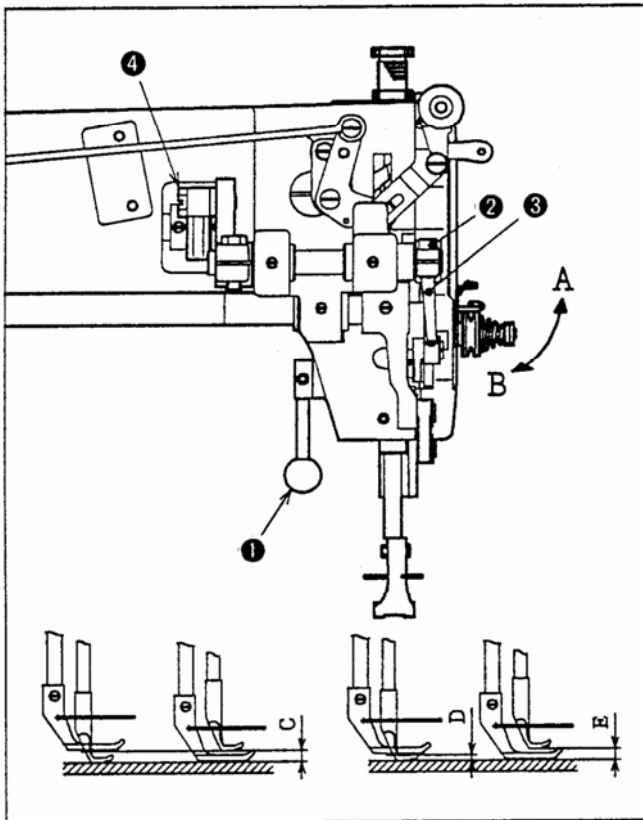

★ Alternate vertical motions of the walking foot and the presser foot

1. The alternate vertical stroke of the walking foot and the presser foot are normally equal.
2. Depending on the type of material, however, the vertical stroke of the presser foot and walking foot should be changed.
3. For instance, when sewing slippery material or sewing many overlapping section, a better result may be obtained by adjusting the vertical stroke of the walking foot larger than that of the presser foot.
 - (1). Turn the handwheel by hand until the thread take-up reaches its lowest point.
 - (2). Lower hand lifter ① .
 - (3). Loosen screw ② .
 - (4). As you move top feed crank ③ to the left (in direction A), the vertical stroke of the presser foot decreases "D", whereas the vertical stroke of the walking foot increases "E".
 - (5). On the contrary, as you move the top feed crank to the right (in direction B), the vertical stroke of the walking foot becomes closer "C" to that of the presser foot when the walking foot sole in contact with the throat plate surface.
 - (6). After adjustment, securely tighten screw ② .

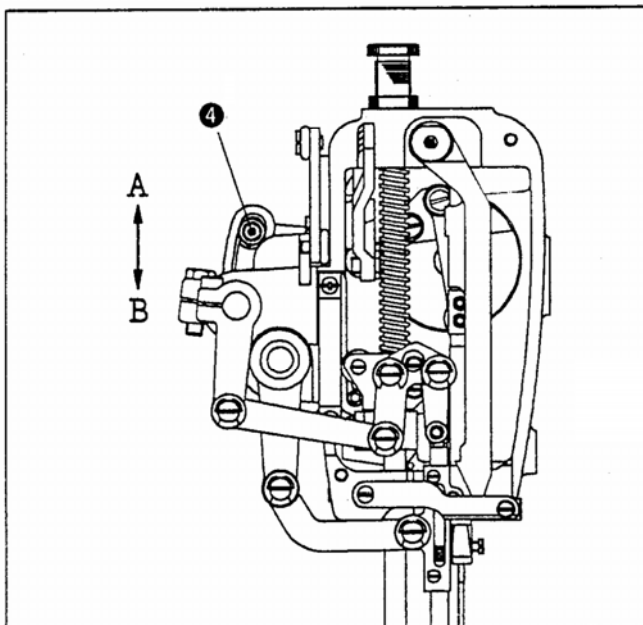

★ Height of the walking foot and the presser foot

1. When sewing elastic material or overlapping sections, a better result may be obtained by changing the height of the presser foot and walking foot.
 - (1). Loosen hinge screw ④ .
 - (2). When you move the cam rot boss toward "A" within the slot, the height is decreased.
 - (3). When you move it toward "B", the height is increased.
 - (4). After adjustment, securely tighten hinge screw ④ .

17. ADJUSTING THE NEEDLE-TO-SHUTTLE RELATIONSHIP

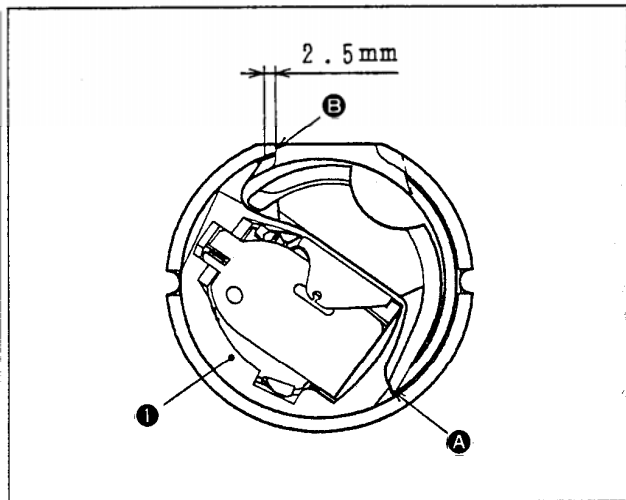

★ **The position of the shuttle when it is recessed most.**
When shuttle ① turns counterclockwise until it will go no further and the shuttle and the shuttle race come in contact with each other at point A a distance of 2.5 mm should be provided between the blade point of the shuttle and end face B of the shuttle race.

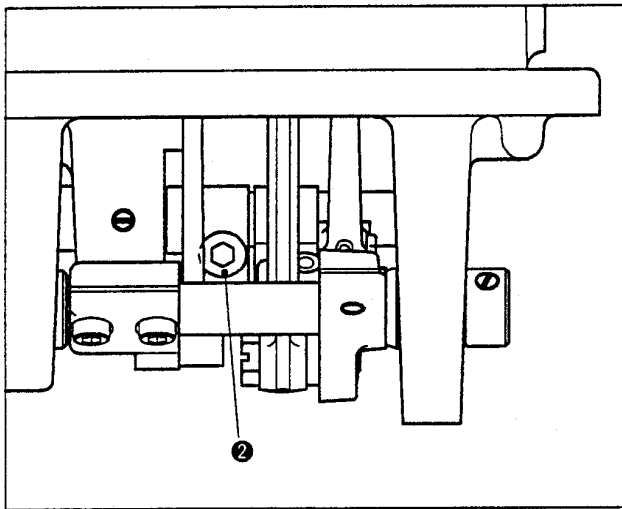

To adjust the position of the shuttle being pulled:

1. Turn the handwheel and stop turning when the shuttle turns counterclockwise until it will go no further.
2. Loosen screw ②.
3. Align the blade point of the shuttle by turning the shuttle by hand.
4. After adjustment has been completed, tighten screw ② firmly.

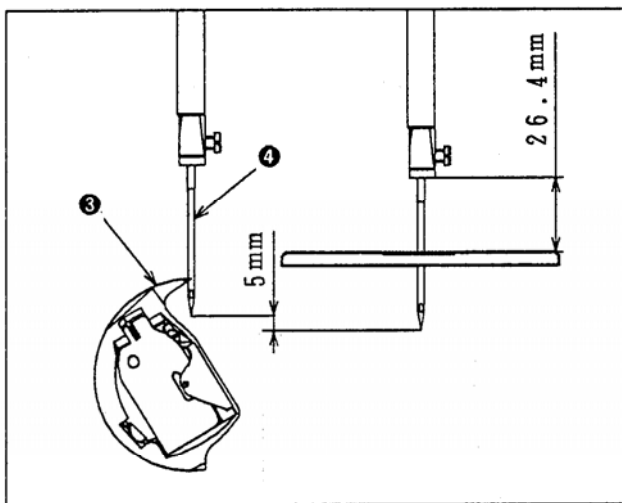

★ Positioning the needle and shuttle

Set the stitch length dial at "0".

Adjust the needle-to-hook relation so that blade point ③ of the hook is aligned with the center of needle ④ when the handwheel is turned toward you until the needle bar ascends from its lowest point by 5 mm.

(Reference value of the lowest position of the needle bar stroke)

The distance from the upper surface of the throat plate to the lower end of the needle bar should be 26.4 mm with the feed pitch set to 0 mm.

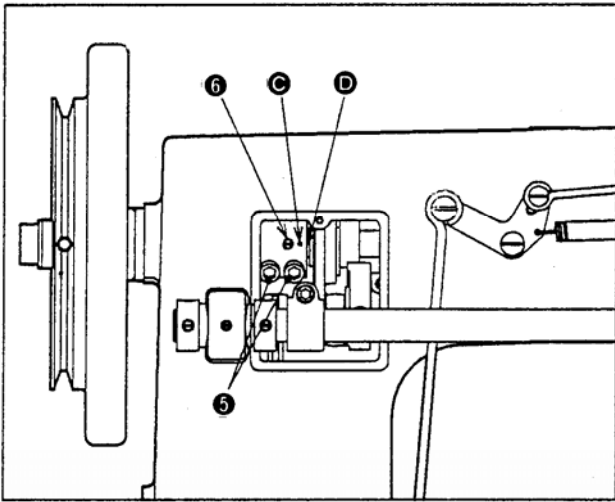

To adjust the position of the needle and shuttle

1. Loosen screw (B) ⑤ .
2. Loosen screw (A) ⑥ , and adjust so that marker dot ③ engraved on the eccentric cam of the vertical rod is aligned with marker line ④ engraved on the main shaft. Then, tighten screw ⑥ .
3. Turn the handwheel toward you, and check the lifting amount of the needle bar.
4. After the adjustment, securely tighten screws ⑤ and ⑥ .

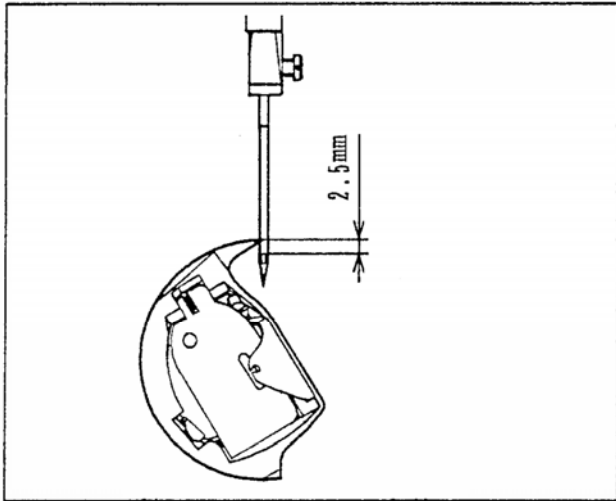

★ **The height of the needle bar**

The correct height is that the distance from the blade point of the shuttle to the upper end of the needle eyelet is 2.5 mm when the blade point of the shuttle is aligned with the center of the needle.

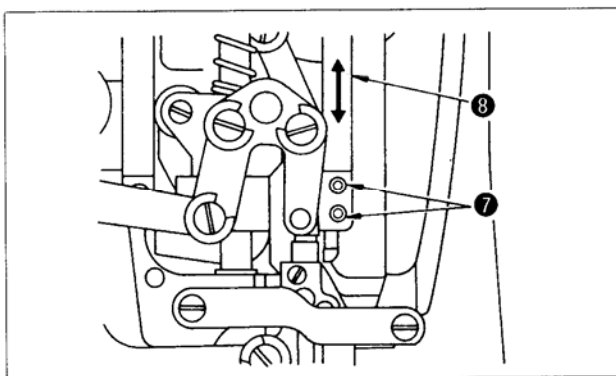

To adjust the height of the needle bar:

1. Set the stitch length dial at 0 mm.
2. Turn the handwheel and stop turning it when the blade point of the shuttle is aligned with the center of needle.
3. Loosen screws ⑦ .
4. Adjust the height by moving needle bar ⑧ up and down.
5. After adjustment has been completed, firmly tighten screws ⑦ .

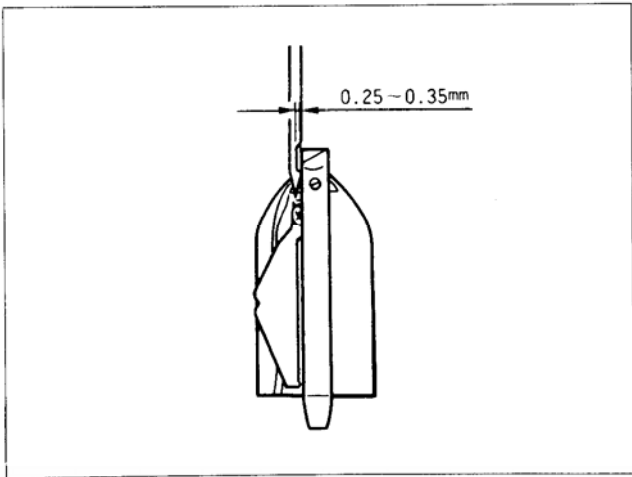

★ **The needle-to-shuttle clearance**

The clearance between the recess in the needle and the blade point of the shuttle has already been adjusted to 0.25 ~ 0.35 mm.

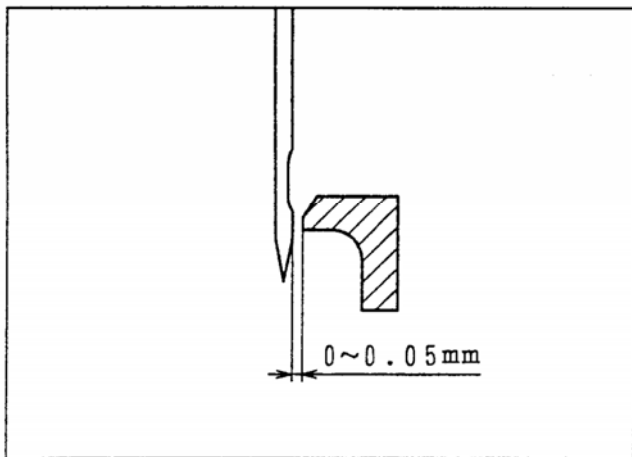

★ **Clearance between the needle and the shuttle driver**

The clearance between the needle and the needle guide of the shuttle driver has already been adjusted to the range of 0 through 0.05 mm.

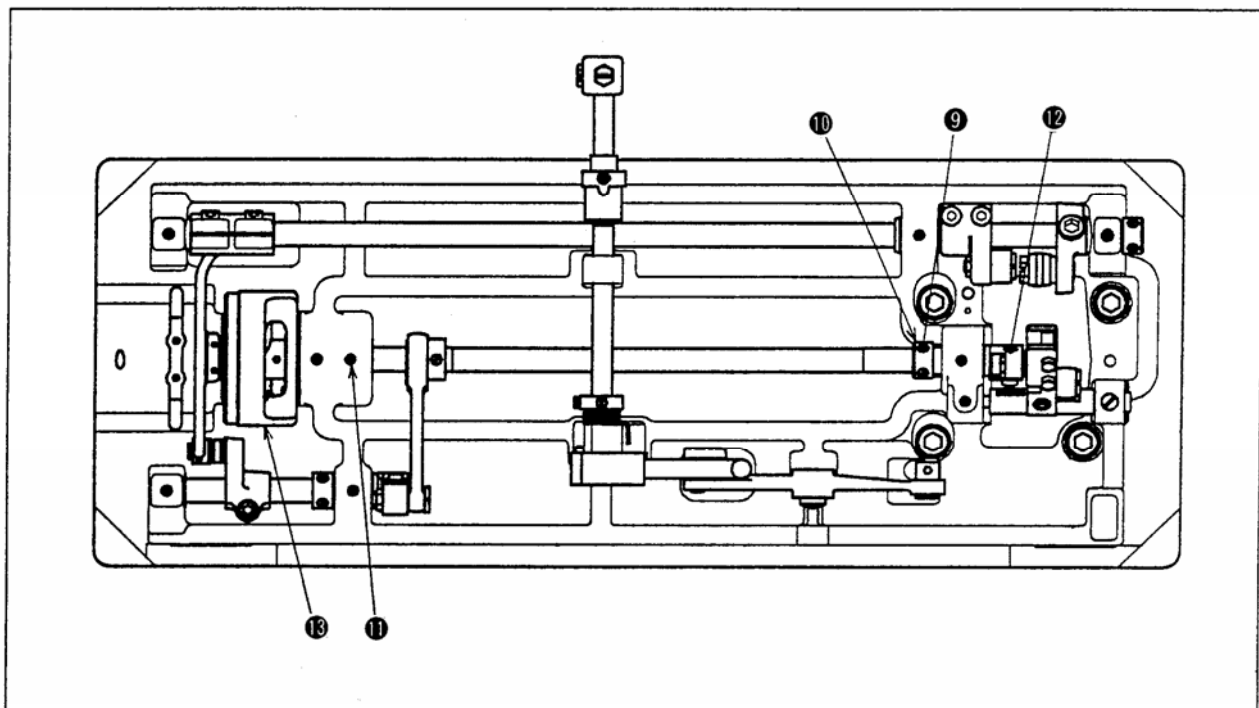

★ **To adjust the clearance between the needle and the shuttle driver**

1. Loosen two screws ⑨ , and move thrust collar ⑩ of the shuttle driving shaft.
2. Loosen two screws ⑪ in the shuttle driving shaft front bushing and small pendulum clamping screw ⑫ .
3. Adjust the clearance by moving shuttle driving shaft front bushing ⑬ to the left and right.
4. After the adjustment has been completed, secure the shuttle driving shaft thrust collar and the small pendulum, making sure there is no axial play of the shuttle driving shaft.

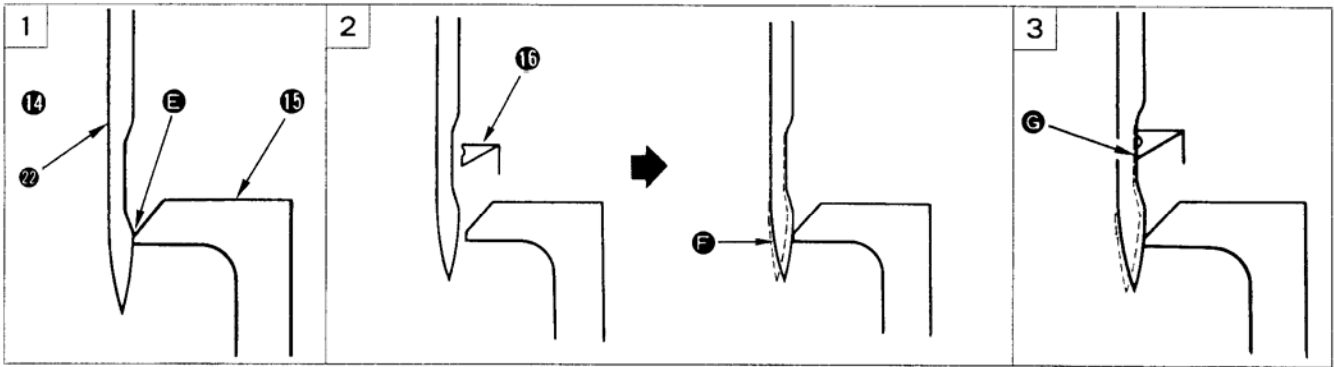

[The standard for adjusting the clearance between the needle and the blade point of the shuttle]

Use a standard Schmetz 794-Nm230 needle.

1. Adjust the clearance **E** between the convex section of needle **14** and shuttle driver **15** to 0.
2. Align the needle center with the blade point of shuttle **16** and press the **F** section of the needle against the shuttle driver.
3. Adjust the clearance **G** to a minimum, with the needle pressed against the shuttle driver, making sure that the needle does not contact the blade point of the shuttle.

* By this adjustment the needle-to-shuttle blade point clearance will be 0.25 ~ 0.35 mm.

18. THE FEED DOG-TO-NEEDLE RELATIONSHIP

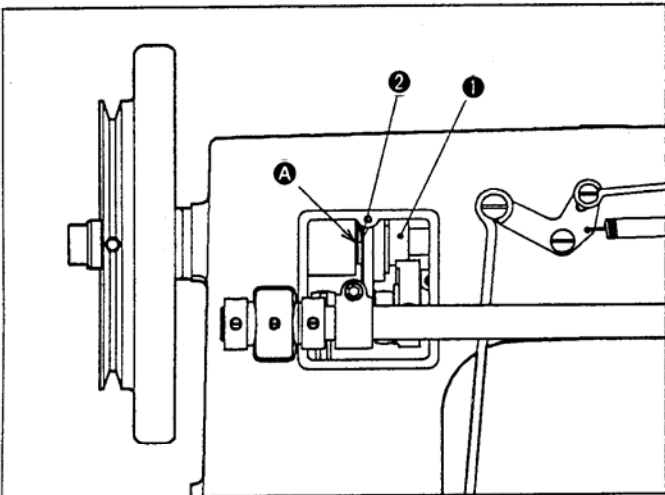

As standard timing of the feed dog, when the center of the needle aligns with the blade point of the shuttle with the feed pitch set to "0", the feed dog should move from right to left by 1 mm when observed from the face plate by moving the feed lever from the position to set the normal feed pitch to the maximum value to the position to set the reverse feed pitch to the maximum value.

★ To adjust the timing:

1. Loosen the two screws for the feed eccentric cam **1**.
2. Adjust the timing to the standard one by aligning the top end of screw No. 1 **2** in the feed eccentric cam with marker line **A** engraved on the main shaft.
3. After adjusting the timing has been completed, firmly tighten the two screws for the feed eccentric cam.



19. THE MOTOR PULLEY AND THE V BELT

Sewing speed of the machine (s.p.m.)	4P			
	50 Hz		60 Hz	
	Motor pulley O.D.	Belt length	Motor pulley O.D.	Belt length
600	65 mm	55 inches	55 mm	49 inches
800	85 mm	56 inches	70 mm	50 inches

1. Use an M-type motor pulley and V belt.
2. The relationship between the motor pulley/belt length and the sewing speed of the machine is shown in the table on the right.

(Caution) When using a single phase motor, use belts of 1 inch longer than those shown in the right-hand table.

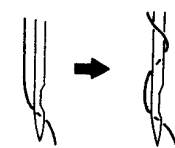
20. PROBLEMS WITH SEWING AND CORRECTIVE MEASURES

Problem	Cause	Corrective measures
<p>1. Thread often breaks or thread splits finely, correct stitch cannot be formed (half-finished stitch)</p>	<p>① Flaw is found out at thread path, needle point, shuttle blade point, or needle eyelet. ② Improper finish around the recess in the needle. ③ Excessively tightened needle thread tension ④ The needle interferes with the blade point of the shuttle. ⑤ The timing of the needle and the shuttle is too early or too slow. ⑥ Due to heat generated by the needle. ⑦ Excessive height difference at stepped section.</p>	<ul style="list-style-type: none"> ○ Remove flaw by smoothing flaw with fine paper file. ○ Replace the needle with a new one. ○ Adjust the needle thread tension. ○ Refer to "17. Adjusting the needle-to-shuttle relationship". ○ Refer to "17. Adjusting the needle-to-shuttle relationship". ○ Decrease the sewing speed of the machine. Use silicone oil. ○ Increase the amount of movement of the thread take-up spring.
<p>2. Stitches are frequently skipped</p>	<p>1. The needle-to-shuttle blade point clearance is excessive. 2. The timing of the needle and the shuttle is too early or too slow. 3. The presser bar pressure is insufficient. 4. The distance from the upper end of the needle eyelet to the blade point of the shuttle is not proper. 5. The needle is improperly selected. 6. The amount of movement of the thread take-up spring is excessive. 7. Overheated needle or shuttle. Thread is not pulled smoothly. 8. Reverse stitching is made at low speed on light weight material using nylon thread.</p>	<ul style="list-style-type: none"> ○ Refer to "17. Adjusting the needle-to-shuttle relationship". ○ Refer to "17. Adjusting the needle-to-shuttle relationship". ○ Tighten the presser adjuster screw. ○ Refer to "17. Adjusting the needle-to-shuttle relationship". ○ Replace the needle with a one-count lower needle. ○ Decrease the amount of movement of the thread take-up spring. ○ Use silicone oil. ○ Wind the needle thread around the needle. <div style="text-align: center; margin-top: 10px;">  </div>
<p>3. Improper thread tension, irregular stitch, excessive bobbin thread tension</p>	<p>① The needle hole in the walking foot, needle hole in the feed dog or thread path in the thread guides has scratches. ② The bobbin slides unsmoothly. ③ Weak bobbin thread tension. ④ Bobbin thread is wound too tightly. ⑤ Needle thread flaps. (Needle thread flaps and comes out of the thread tension disc due to excessive needle thread tension or is caught in other parts.) ⑥ Too thin bobbin thread is used to combine with needle thread.</p>	<ul style="list-style-type: none"> ○ Smooth the surface with a fine paper file or using a buff. ○ Replace the bobbin or the shuttle. ○ Adjust the bobbin thread tension. ○ Decrease the tension of the bobbin thread winder. ○ Thread the tension guide bar as illustrated right. ○ Use silicone oil. <div style="text-align: center; margin-top: 10px;">  </div>
<p>4. Poor gloss of the needle thread</p>	<ul style="list-style-type: none"> ○ Excessive height difference at stepped section. 	<ul style="list-style-type: none"> ○ Use silicone oil.

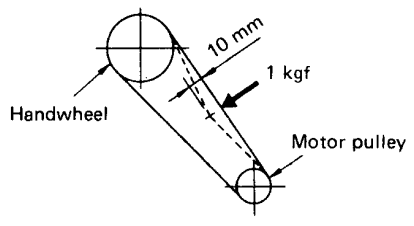
Problem	Cause	Corrective measures
5. Inconsistently finished seam (stitches are not made straight but made such as “ ≡ ”)	○ Needle is too thick.	○ Replace the needle with a thinner one. Use cutting point needle 
6. Bobbin thread tension cannot be increased.	○ The bobbin thread tension spring of the shuttle has become dusty or dirty.	○ Clean by removing the bobbin thread tension spring.
7. The belt slips (Motor stoppage occurs, if an electronic-stop motor is used.)	① The V belt is degraded. ② The V belt tension is not enough.	○ When degradation is found out to the V belt, such as wear, cracking, etc., replace with a new one. ○ Adjust the slack amount in the V belt to 10 mm/1 kgf. 

Distributor: